

[The selection is detailed on page 5](#)



A12

Bourdon Tube Pressure Gauge

Working principle

Bourdon tube pressure gauges are the most commonly used mechanical pressure measuring instruments. Its pressure element is often referred to as Bourdon tube:

In the mid-19th century, French engineer Eugene Bourdon applied this functional principle. It is based on an elastic spring, a C-shaped, curved tube with an elliptical cross section. When the inner space of the Bourdon tube is compressed, the cross section changes towards the circle. The circumferential stress generated during this process increases the radius of the C-shaped tube. As a result, the end of the tube moves about two to three millimeters. This deflection is a measure of pressure. The pressure is converted into displacement, which turns the linear deflection into a rotational displacement and makes it visible on the scale through the pointer.

Product description

The A12 gauge is based on the proven Bourdon tube measuring system. When pressurized, the deflection of the Bourdon tube is proportional to the incident pressure and transmitted to the transmission movement through the link. The modular design enables a variety of combinations of case materials, process connections, nominal sizes and ranges. Its diversity makes the gauge suitable for a wide range of industrial applications. When mounted on the control panel, the pressure gauge can be equipped with a surface mount flange or triangle stop and mounting bracket. (depends on process connection)

Product application

For pneumatic/hydraulic/Marine/compression/heating systems
 For measuring gaseous or liquid media that do not stick, crystallize or corrode stainless steel parts
 Heating and air conditioning technology
 Medical engineering

Functional characteristics

Reliable and cost-effective
 The design conforms to EN837-2 standard
 Strong steel or stainless steel housing



Technical parameter

Design	Meets the EN837-3 standard
Standard size (mm)	60
Precision class	NS 60: 1.6
Range	NS 60: -1... 0 to -1... +15bar; 0... 0.6 to 0... 400bar
Pressure limit	
▪ Static pressure	Static pressure: 3/4x full scale value
▪ Dynamic pressure	Dynamic pressure: 2/3x full scale value
▪ Dynamic pressure	Instantaneous pressure: full scale value
Allowable temperature	
▪ Environment	- 20... + 60 °C
▪ Medium	The maximum is +60°C
Temperature effect	When the temperature of the measuring system fluctuates around the reference temperature (+20 °C), the maximum change is $\pm 0.4\%$ /10K of the range
Class of protection	IP32, in accordance with EN 60529
Connection material	Stainless steel
Installation mode	Radial or axial
Process connection	NS 60, G1/4B, SW14
Pressure element	Copper alloy bourdon tube 60 bar "C" shaped tube > 60 bar spiral tube
Drive movement	Copper alloy
Dial plate	White plastic Dial dial word black
Pointer	Black plastic
Shell	Stainless steel 304 metal
Watch glass	The clear plastic card is housed in the housing
Optional parameter	Front side or back side mounting Three hole surface mounting flange Single and double scale optional Other process connection Overvoltage device Precision class

Size mm

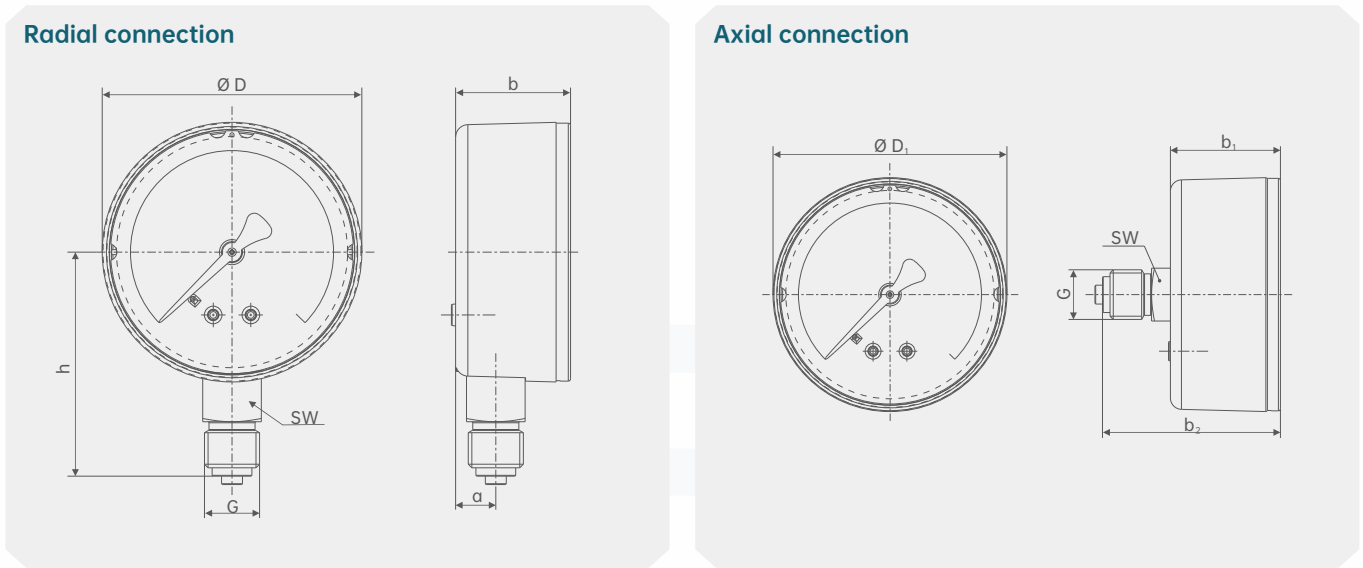

Radial connection

NS	Size mm						Weight kg
	a	$b \pm 0.5$	D	G	$h \pm 1$	SW	
60	9.5	27.5	62	G1/4B	53.5	14	0.13

Axial connection

NS	Size mm					Weight kg
	$b \pm 0.5$	$b_2 \pm 1$	D	G	SW	
60	29	47	62	G1/4B	14	0.08

Range table

Negative pressure	code	MPa	code	Bar	code	kPa	code	kg/cm ²	code	Psi/-inHg
	MV001	-0.1/0	BV001	-1/0	KV001	-100/0	GV001	-1/0	RV030	-30"/0 Hg
Positive and negative pressure	code	MPa	code	Bar	code	kPa	code	kg/cm ²	code	Psi/-inHg
	MC006	-0.1/0.06	BC006	-1/0.6	KC006	-100/60	GC006	-1/0.6	PC015	-30"/0/15
	MC015	-0.1/0.15	BC015	-1/1.5	KC015	-100/150	GC015	-1/1.5	PC030	-30"/0/30
	MC030	-0.1/0.3	BC030	-1/3	KC030	-100/300	GC030	-1/3	PC060	-30"/0/60
	MC050	-0.1/0.5	BC050	-1/5	KC050	-100/500	GC050	-1/5	PC100	-30"/0/100
	MC090	-0.1/0.9	BC090	-1/9	KC090	-100/900	GC090	-1/9	PC160	-30"/0/160
	MC150	-0.1/1.5	BC150	-1/15	KC150	-100/1500	GC150	-1/15	PC200	-30"/0/200
	MC240	-0.1/2.4	BC240	-1/24	KC240	-100/2400	GC240	-1/24	PC300	-30"/0/300
Positive pressure	code	MPa	code	Bar	code	kPa	code	kg/cm ²	code	Psi
	MP001	0/0.1	BP001	0/1	KP001	0/100	GP001	0/1	PP1E5	0/15
	MP1E6	0/0.16	BP1E6	0/1.6	KP1E6	0/160	GP1E6	0/1.6	PP003	0/30
	MP2E5	0/0.25	BP2E5	0/2.5	KP2E5	0/250	GP2E5	0/2.5	PP006	0/60
	MP004	0/0.4	BP004	0/4	KP004	0/400	GP004	0/4	PP010	0/100
	MP006	0/0.6	BP006	0/6	KP006	0/600	GP006	0/6	PP016	0/160
	MP010	0/1	BP010	0/10	KP010	0/1000	GP010	0/10	PP020	0/200
	MP016	0/1.6	BP016	0/16	KP016	0/1600	GP016	0/16	PP030	0/300
	MP025	0/2.5	BP025	0/25	KP025	0/2500	GP025	0/25	PP040	0/400
	MP040	0/4	BP040	0/40	KP040	0/4000	GP040	0/40	PP060	0/600
	MP060	0/6	BP060	0/60	KP060	0/6000	GP060	0/60	PP100	0/1000
	MP100	0/10	BP100	0/100	KP100	0/10000	GP100	0/100	PP150	0/1500
	MP160	0/16	BP160	0/160	KP160	0/16000	GP160	0/160	PP200	0/2000
	MP250	0/25	BP250	0/250	KP250	0/25000	GP250	0/250	PP300	0/3000
	MP400	0/40	BP400	0/400	KP400	0/40000	GP400	0/400	PP400	0/4000

A12-Selection composition

Selection example A12

A	B	E	MP001	N	F	R	Y	M
1	2	3	4	5	6	7	8	9

1.Dial diameter mm	A	63
2.Precision class	E	1.0
	B	1.6
	C	2.5
3.liquid-filled	D	Glycerin
	E	Silicone oil
	N	Without
4.measuring range	-	See range table (page 4)
5.Second range unit	G	MPa
	H	Bar
	I	KPa
	J	Kg/cm ²
	K	Psi
	N	Without
6.Process connection	F	1/4NPT
	O	M10*1.0
	P	M14*1.5
	Q	G1/4B
	T ()	Other specifications
7.Installation mode	R	Radial direction
	S	Axial direction
	W	Radial front edge (three-hole mounting)
	U	Shaft forward edging (three-hole mounting)
	V	The shaft is mounted on the rear bracket
8.Watch glass	X	PC plastic
	Y	Safety glass
9.Material	S	Stainless steel
	M	304SS
	L	316L
	T ()	Other materials
10.Special requirements	A	Degrease
	B	Oxygen application ≤160bar
	N	Without
11.Certificate	C	2.1 Measurement report
	D	3.7 Inspection certificate
	N	Without
12.Additional description	H	There are
	N	Without

Instructions:

It indicates that the dial diameter of A12 pressure gauge is 63mm, the accuracy class is 1.6%, the shockproof is filled with silicone oil, the measuring range is 0~0.1MPa, no second measuring range unit, the process connection is 1/4NPT, the radial installation, the safety glass, the body material is 304SS. Items 10/11/12 in the above table are not required

Product Certification

Compliance and approval; Rodewieg pressure meets key standards and certifications for process measurement technology; Thus guaranteeing the highest reliability in such Settings;