

The selection is detailed on page 10



DB12

Surface Welded Type Thermal Resistance

Working principle

Thermal resistance is a temperature measuring element commonly used in low and medium temperature areas, using the resistance of the substance itself to measure the temperature when the temperature changes. The heated part of the thermal resistance (temperature sensing element) is evenly wound on the skeleton made of insulating material with a thin metal wire. When there is a temperature gradient in the measured medium, the measured temperature is the average temperature in the medium layer within the range of the temperature sensing element.

Product description

probe

The probe is mounted in a heat collecting block to meet a variety of flat surface measurement requirements. The collector can be threaded or welded to the surface of the container.

cable

Cables are available in a variety of insulating materials to meet the application requirements of specific environmental conditions. The end of the cable has been prefabricated and can be directly connected, of course, customers can also choose connectors or connect the cable to the field junction box according to their needs.

Functional characteristics

Application range: Up to 250°C(optional: 600°C)

Easy to replace, no jacket required

Installation can be done using threaded, welded or bundled cable ties

Cables are made of PVC, silicon or PTFE

Explosion proof type

Product application

Used to measure surface temperature on flat surfaces or pipes in laboratory and industrial applications



Working principle
Analytic table

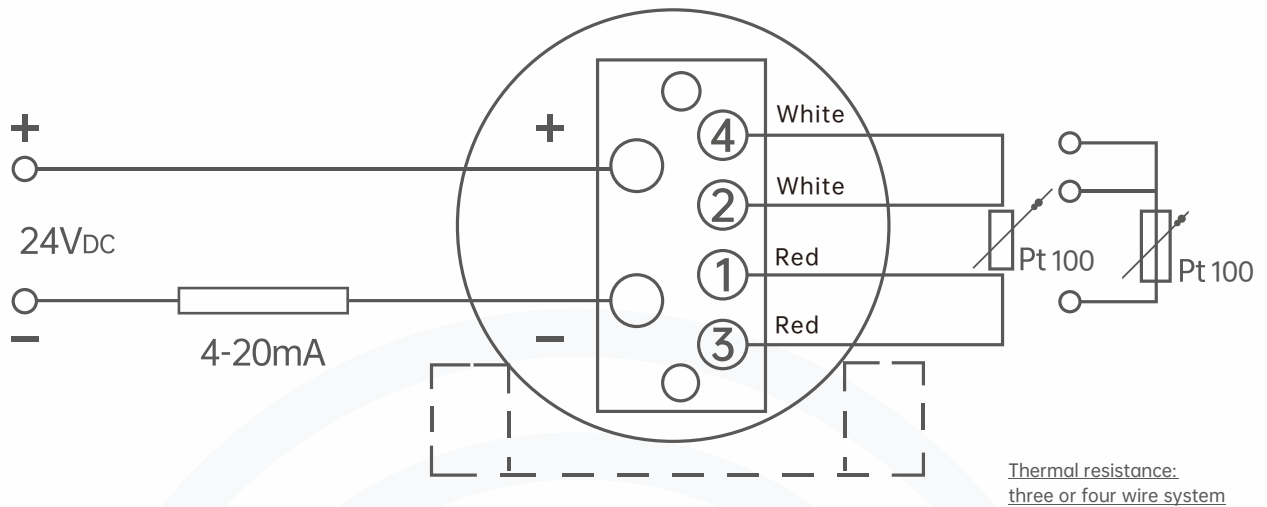

Sensor

The sensor is located at the tip of the probe.

Sensor connection mode

- Two-wire system
- Three-wire system
- Four-wire system

Sensor tolerance values, according to DIN EN 60751

- Grade B
- Level A
- Grade AA

It is not permitted to use 2-wire connections with class A or AA accuracy because measuring the lead resistance of the probe rod can adversely affect sensor accuracy.

Metal probe

Specification parameter

- Material: Stainless steel
- Diameter: 3 or 6 mm
- Length: Optional

Regardless of the design, the sensor front 60mm does not allow bending.

Surface welded resistance thermometers are constructed in two different ways:

Pipe profile design

The metal probe with tubular design adopts rigid structure; Therefore, do not bend tubular design products.

The measuring resistance is internally connected directly to the insulated wire; Therefore, the tubular design of the thermal resistance thermometer can only be used below the corresponding temperature of the wire (see operating temperature).

Armor design

In armored type thermal resistance thermometers, the flexible part of the sensor is a mineral insulated cable (MI cable).

It consists of high density ceramic compound, coupling wire and stainless steel outer sheath. The measuring resistance element is connected directly to the lead inside the armored cable, so this design is particularly suitable for high temperature conditions. Because armored resistance thermometers are flexible and can be made small in diameter, they can be used in less accessible locations. Armored cables can be bent to a maximum radius of three times the diameter of the wire, except where the probe and the tube seal connecting the cable are located.

Maximum operating temperature

The maximum operating temperature of these thermometers is affected by several parameters. If the operating temperature exceeds the allowable temperature of the connecting cable, connector, or filling duct, the metal portion of the sensor (mineral insulated cable) must be long enough to keep the critical component out of the high-temperature area. The minimum maximum operating temperature requirements for connecting cables, filling ducts, or connectors specified here must be met.

Sensor

Measuring element

Pt100, Pt1000¹⁾ (Measuring current: 0.1...1.0 mA)

Connection mode	
unitware	1 x 2 Wire system
	1 x 3 Wire system
	1 x 4 Wire system
two-element	2 x 2 Wire system
	2 x 3 Wire system
	2 x 4 Wire system ²⁾

Measuring rod tolerance values, according to EN 60751		
category	Sensor structure	
	Winding form	Film type
B level	-196 ... +600°C	-50 ... +500°C
	-196 ... +450°C	-50 ... +250°C
A level ³⁾	-100 ... +450°C	-30 ... +300°C
AA level ³⁾	-50 ... +250°C	0 ... 150°C

1) Pt1000 Can only be used as thin film measuring resistance; 2) Diameter is not 3mm; 3) Not suitable for 2-wire wiring

Connect cables and single wires

At any position on the connection cable, the maximum temperature that can be tolerated refers to the temperature specified by the connection cable. The sensor (see above) may itself be capable of withstanding higher temperatures. For common connection wires, refer to temperature limits:

PVC: -20 ... +100 °C

Silicone: -50... +200 °C

PTFE: -50 ... +250 °C

Glass fiber: -50... +400 °C

Therefore, for tubular designs, if an insulated cable is installed inside the metal probe, the upper operating temperature limit for the connecting cable still applies.

Coupler

When optional connectors are installed, the maximum permissible temperature at the connector is:

Lemos: -55 ... +250 °C

Binder: -40 ... +85 °C

From the metal part of the thermometer to the glue tube connecting the cable

The temperature of the filling tube is further limited by the sealant used.

Sealant temperature range: -40... 150 °C

Optional: 250 °C

'Other models are available on request'

Special low temperature version temperature range: -60... +120 °C⁴⁾

4) Available only with the selected certification

Operating temperature

If the temperature to be measured is higher than the allowable temperature at the cable, connector, or duct, the metal part of the probe must be long enough to extend beyond the hot area. It should be noted that the maximum operating temperature of the cable, filling duct or connector should not be exceeded.

Glue filling catheter

Depending on the design, the contact between the metal part of the probe and the connecting cable or wire may be rolled or glued in different forms. The area should not be immersed in the process and must not be bent. The movable sleeve should not be fixed to the filling duct. The type and size of the filling tube depends largely on the combination of wire and metal sensor and sealing requirements.

SizeT Indicates the length of the filling tube

Standard	Size T ⁵⁾ (mm)	Glue filling catheter Ø (mm)
Probe Ø = filling tube Ø	n/a	Probe equal
Ø2 ... 4.5 mm (With pressed glue filling catheter)	45	6
Ø6 mm (With pressed glue filling catheter)	45	7
Ø6 mm (With pressed glue filling catheter) ⁶⁾	45	8
Ø8 mm (With pressed glue filling catheter)	45	10

The filling duct with operating temperature < -40°C is designed as follows

Standard	Size T (mm)	Glue filling catheterØ (mm)
Probe Ø = Glue filling catheter Ø	n/a	Probe equal
Ø2 ... 4.5 mm (With pressed glue filling catheter)	60	8
Ø6 mm (With pressed glue filling catheter)	60	8
Ø8 mm (With pressed glue filling catheter) ⁶⁾	60	10

5) For the 2 x 4 wire sensor connection mode, the length of the glue filling catheter is generally 60 mm;

6) With a large number of wires (such as 2 x 3 wires and sheathing)



Glue filling catheter

Connecting lead

A variety of insulation materials are available to meet the needs of various environmental conditions. The end of the cable is prefabricated and can be connected directly or fitted with a connector or connected to a field junction box (optional).

Connecting cable (standard)

Cable material: Copper (wire)
 Cable cross-sectional area: about 0.22 mm² (standard design)
 Number of cables: depends on the connection mode
 Insulation material: PVC, silicone, PTFE or glass fiber
 Shielding layer (optional)

Class of protection

Standard type: IP65 Max
 (Depends on cable sheath material and number of cables)

Special type (subject to customer requirements) : IP67 Max
 Connection leads with fiberglass sheathed do not offer explosion-proof design.

Process connection

Metal collector block

Design: Contact blocks that can be screwed or welded to flat surfaces
 Material: Stainless steel
 Dimensions: See drawing

Washer type

Design: Center borehole washer
 Material: Stainless steel
 Dimensions: See drawing

Clamp installation

Design: Clamp mounting
 Material: Stainless steel
 Dimensions: See drawing

Solder strip

Design: Welded sheet
 Material: Stainless steel
 Dimensions: See drawing

Size mm

Bending direction (MI cable)

- 1 Standard with straight shape
- 2 Standard 90° bend
- 3 Standard 45° bend
- 4 Options
- 5 Options

Metal collector (with mounting holes)

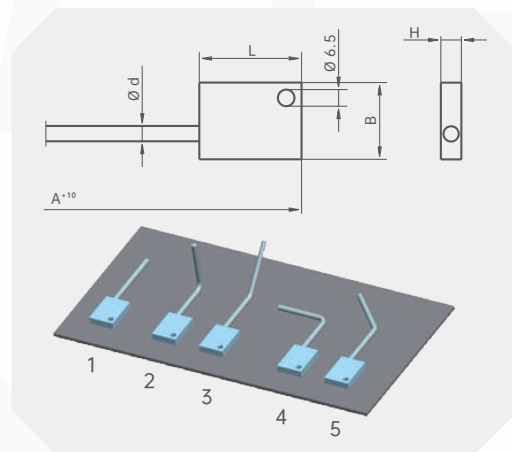

Washer type

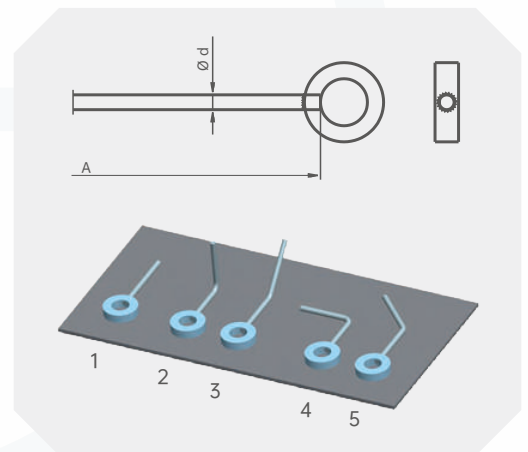

Clamp installation

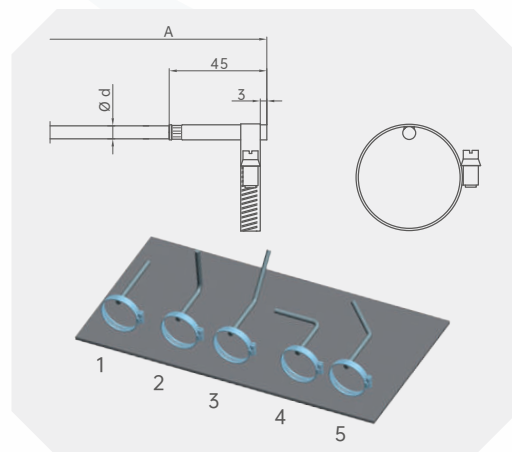

Solder strip

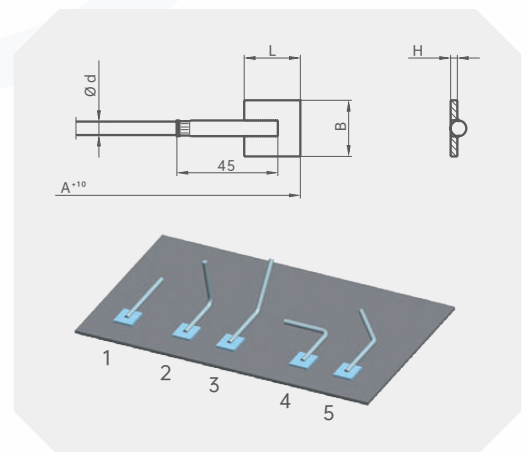

Size mm

Process connection	Size (mm)	
	Width x length x height	Outer diameter x inner diameter x thickness
	(B×L×H)	(AD×ID×d)
Metal collector (aperture d=6.5mm)	30×40×8	-
Washer type	-	38.1×19.1×9.5
Solder strip 25×25×3.0	25×25×3.0	-
Clamp installation	-	11...15
	-	13...25
	-	23...62
	-	60...93
	-	91...125
	-	123...158

Cable end design

According to the electrical connection characteristics, it can be divided into the following types:

- Wire connection
- Connecting cables
- Connection cable with connector
- Design with bare connection cables
- The connector is designed to be mounted directly onto the probe
- Connect the field junction box

Dimension A indicates the probe length. Dimension W indicates the cable length. L indicates the length of the bare end of the cable. Size T indicates the size of the connecting conduit (if any). T is always part of length W or L.

Cable end design Wire connection

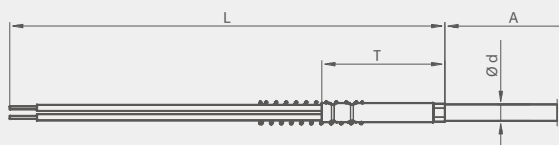

Wire connection

Wire length is 150mm (other lengths can be provided according to customer requirements) 0.22mm² copper core (PTFE or glass fiber insulation), the number of leads depends on the number of sensors and sensor connection, bare wire end (other designs can also be provided according to customer requirements)

Cable end design Connecting cable

Connecting cable

The cable and probe are permanently connected to each other. Cable length and insulation materials are subject to customer specifications. 0.22 mm² copper core, the number of leads depends on the number of sensors and sensor connection, bare wire end

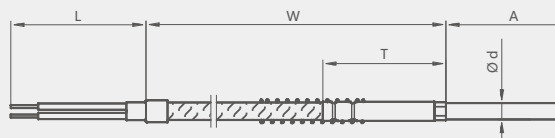

Cable end design
Connection cable
with connector

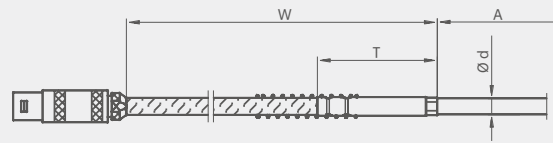

Connection cable with connector

Optional connectors can be installed on flexible connection cables.

Cable end design
Design with bare
connection cables

Design with bare connection cables

The inner leads of mineral insulated cables extend out.
 L = 20 mm (standard)

The length of the bare connection cable can be determined based on user requirements. These bare inner leads are made of solid cables and are therefore not suitable for long distance wiring.

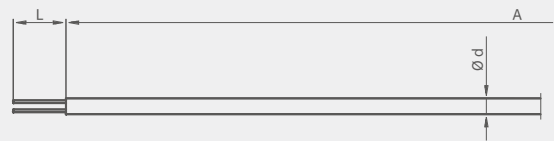

Cable end design
Connectors are mounted
directly to the probe
design

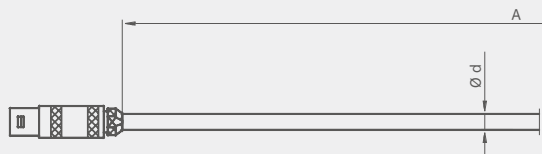

Connection cable with connector

These designs are also based on the bare connection cable design. The connector is mounted directly onto the metal probe.

Cable end design
Connect the field
junction box

Connect the field junction box

The connection cable is connected to the field junction box (ABS plastic) through a single gran head. In addition, a gran head is installed as a cable outlet. Aluminum housing is available.

Enclosure ambient temperature:

- Forty... +80 °C

Granhead material:

- Plastic (standard)
- Metal (optional)

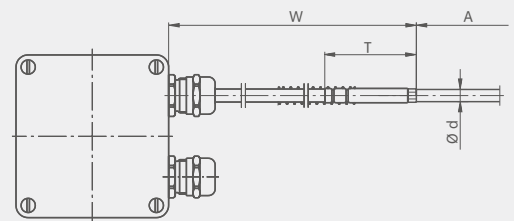

Curved probe

Surface-welded thermal resistance thermometers made of armored cables are available in prefabricated shapes. In this case, the bending position will be determined by another dimension.

Dimension X indicates the distance between the bend point and the bottom of the connecting conduit.

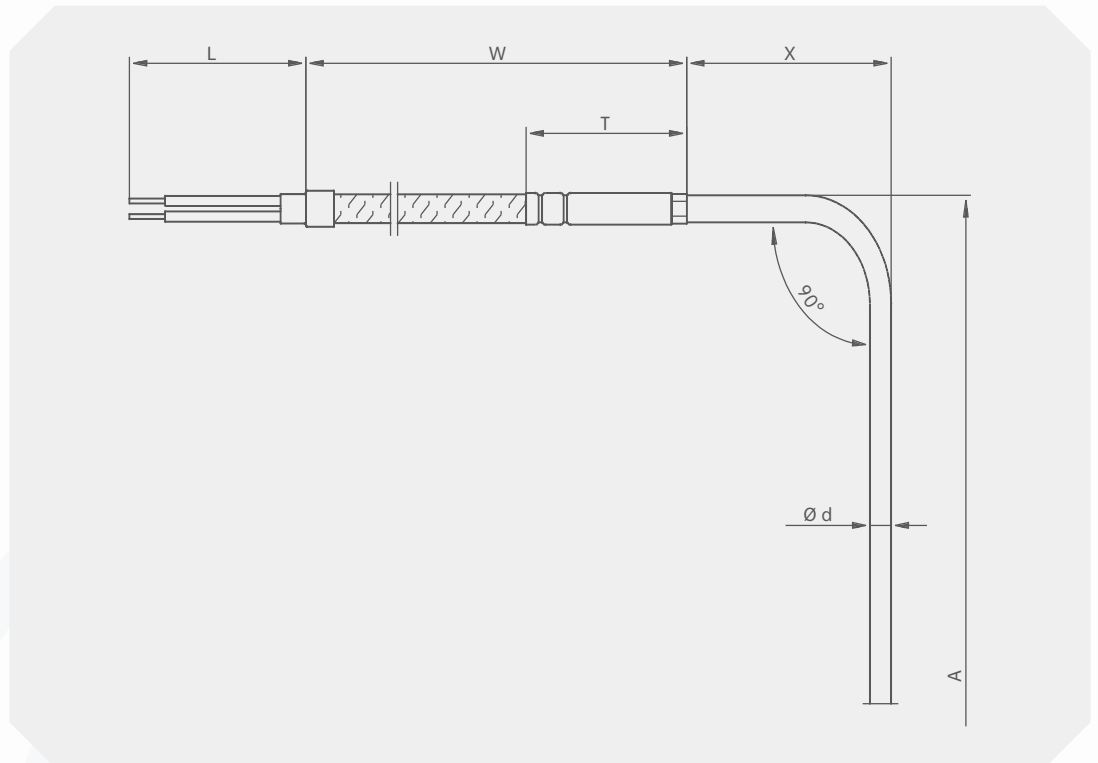

Other bending angles are available on request.

Stress relief rings are available upon request.

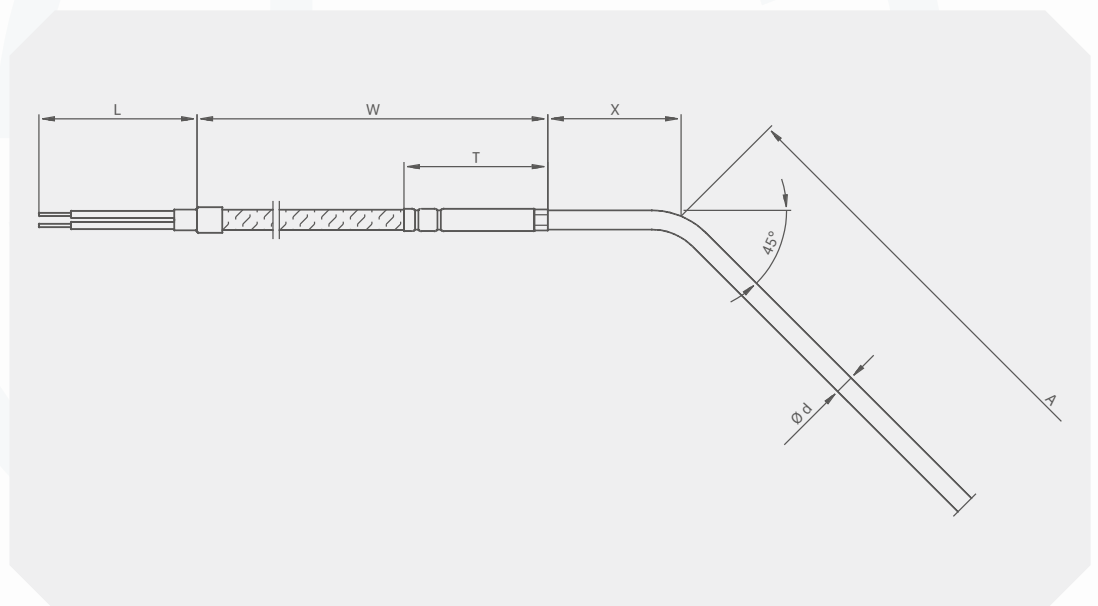

Connector (optional)

Cable type thermal resistors are available with pre-installed connectors.

Users can choose from the following options:

Binder Screw in plug (outside)

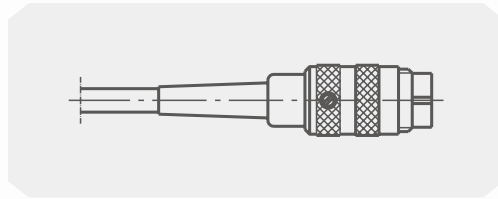

Binder Screw in the plug (inside)

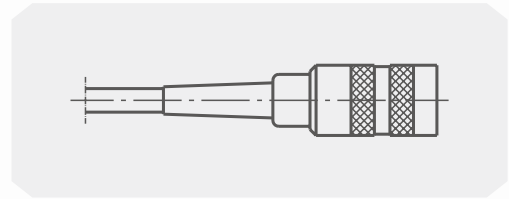

Lemosa 1S Connector (outside)
Lemosa 2S Connector (outside)

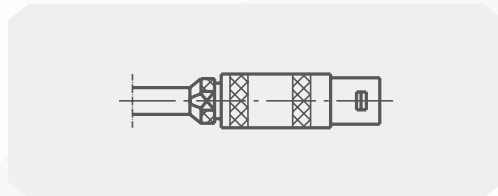

Lemosa 1S Free socket (inside)
Lemosa 2S Free socket (inside)

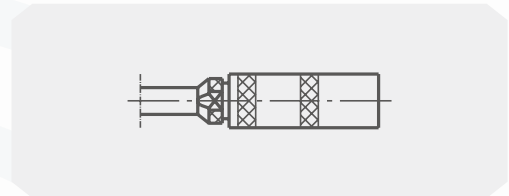

Flat connector (not applicable to products with bare wire connections)

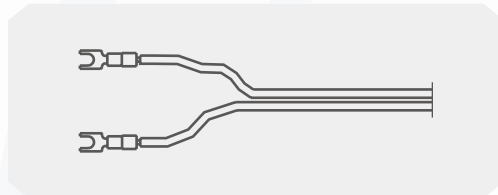

Other types (sizes) of connectors can also be selected according to demand.

Other options

Bend the protective tube

A cable protection tube (spring or heat shrink tube) can be used to protect the transition point between the rigid probe and the flexible connection cable. In applications where relative motion may occur between the cable and the thermometer, appropriate protective measures must be taken.

For Ex n explosion-proof products, a bent protective tube must be used. The standard length of the flexural spring is 60 mm.

Electrical connection

Splice free

1 x Pt100
2 Wire system

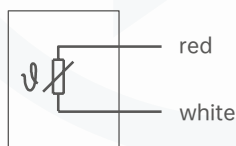

1 x Pt100
3 Wire system

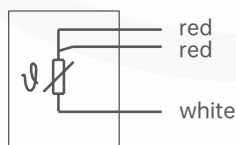

1 x Pt100
4 Wire system

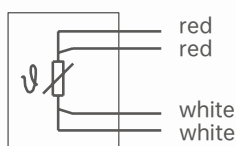

2 x Pt100
2 Wire system

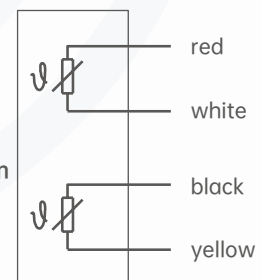

2 x Pt100

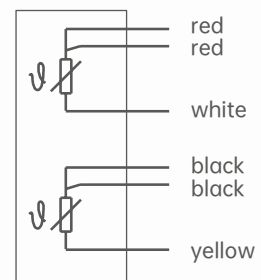

Electrical connection

Lemosa splice

Maximum permissible temperature range: -55 ... +250°C

Joint (external thread)

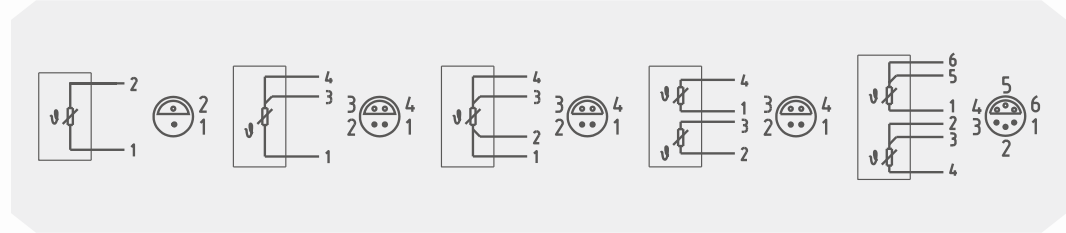
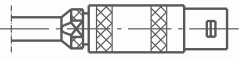

Joint (internal thread)

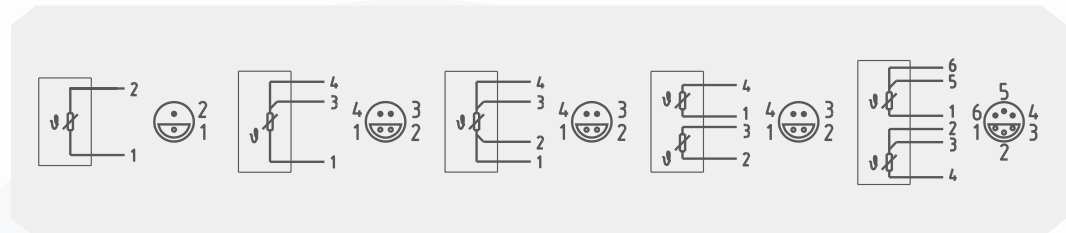
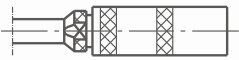

Screw in plug
(Amphenol, Binder)

Maximum permissible temperature range: -40 ... +85°C

Joint (external thread)

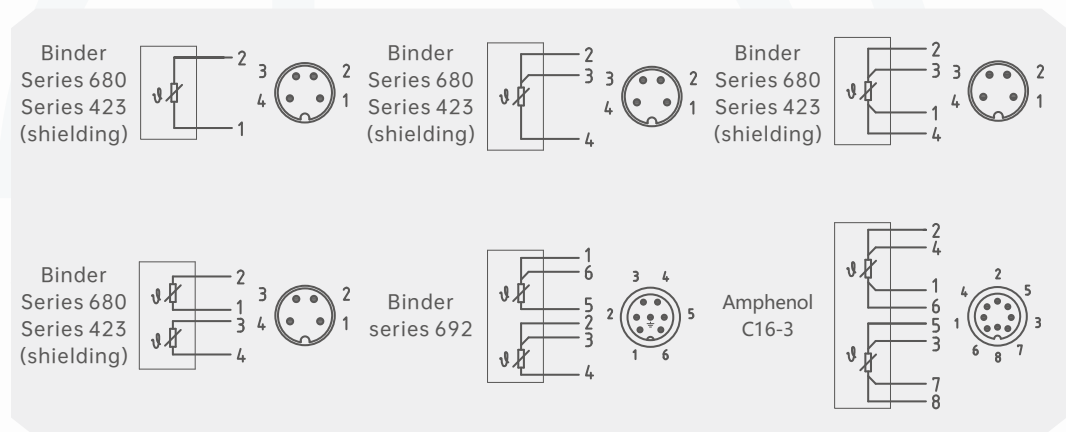
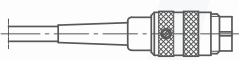

Joint (internal thread)

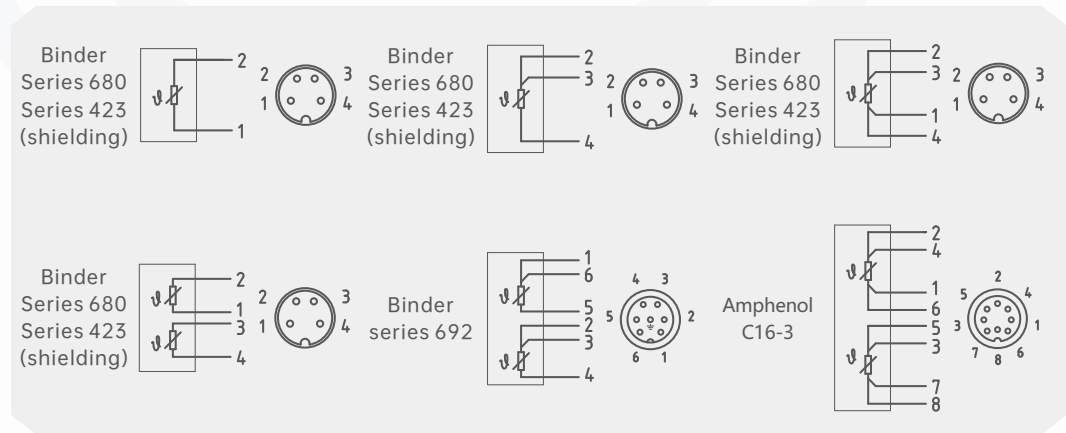
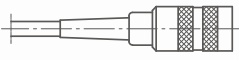

DB12-Selection composition

Selection example Threaded type **DB12** **B** **S** **G** **J** **S** **V** **S** **B** **E** **S** **O** **A** **P** **N**

1 2 3 4 5 6 7 8 9 10 11 12 13 14

1.Selection description	A	All-in-one transmitter
	B	Threaded casing
	C	Intrinsically safe explosion-proof type
	D	Flameproof type
	T()	Other types
2.Threaded connection	S	Sliding thread
	F	Fixed thread
3.Insert probe design	G	Fixed installation
	H	Spring fixed terminal block (replaceable insert)
4.Junction box	I	aluminium
	J	stainless steel
	K	With digital temperature display
	T()	Other types of junction boxes
5.Electrical interface	R	1/2NPT
	S	M20×1.5
6.Wiring block/sensor	U	Crastin Terminal block
	V	Ceramic connection block
	W	S10 (4-20mA transmitter)
	X	S20 (HART transmitter)
	Y	S30 (Fieldbus transmitter)
7.Wire system	S	Single 3-wire system
	T	Double branch 6-wire system
	T()	Other wire system
8.Dimension of thread connection	A	1/2NPT
	B	G1/2
	C	M20×1.5
9.Thermistor	E	Pt100, B level
	F	Pt100, A level
	G	Pt1000, B level
	H	Pt1000, A level
10.Probe rod material	S	304SS
	L	316/316L (1.4401/1.4435)
	T()	Other materials
11.Temperature range (°C)	N	-50...+250
	O	-50...+450
	P	-200...+250
	Q	-200...+450
	R	-200...+600
	S	0...+400
	T	0...+500
	T()	Other measured temperatures

DB12-Selection composition

Selection example Threaded type **DB12** **B** **S** **G** **J** **S** **V** **S** **B** **E** **S** **O** **A** **P** **N**

1 2 3 4 5 6 7 8 9 10 11 12 13 14

12.Rod length (mm)	A	50
	B	100
	C	150
	D	200
	E	250
	F	300
	G	350
	H	400
	I	450
	J	500
T()	Other lengths	
13.Rod diameter (mm)	P	3mm
	Q	4mm
	R	5mm
	S	6mm
	T	8mm
	U	10mm
14.Safety certification	E	Intrinsic safety
	D	Flameproof
	N	There is no
15.Additional order information	X	Additional information
	N	There is no

Instructions:

It means that the DB12 thermal resistance is a thermometer with threaded sleeve, the thread connection mode is sliding thread, the probe rod design is fixed installation, the connection box is stainless steel, the electrical interface is M20*1.5, the sensor is ceramic connection block, the single three-wire system, the thread specification is G1/2, the thermal resistance element is Pt100, the grade B, the probe rod material is 304SS, and the thermal resistance component is PT100. Temperature range -50... 450°C, rod length 50mm, rod diameter 3mm, no explosion-proof, 15 parts are not required.

DB12-Selection composition

Selection example
Flange connection type **DB12** **B S G L V B G N V D G X F N**

1 2 3 4 5 6 7 8 9 10 11 12 13 14

1.Selection description	A	All-in-one transmitter
	B	Flange casing
	C	Intrinsically safe explosion-proof type EEx-i
	D	Flameproof Ex-d
	T()	Other types
2.Flange connection	S	20592 Standard flange
	F	ANSI Standard flange
3.Insert probe design	G	Fixed installation
	H	Spring fixed terminal block (replaceable insert)
4.Junction box	K	Aluminum
	L	Stainless steel
	M	With digital temperature display
	T()	Other types of junction boxes
5.Electrical interface	U	1/2NPT
	V	M20×1.5
6.Wiring block/sensor	A	Crastin Terminal block
	B	Ceramic connection block
	C	S10 (4-20mA transmitter)
	D	S20 (HART transmitter)
	E	S30 (Fieldbus transmitter)
7.Wire system	G	Single 3-wire system
	H	Double branch 6-wire system
	T()	Other wire system
8.Flange connection size	N	DN25
	O	DN50
	P	DN80
	Q	DN100
	R	ANSI 1"
	S	ANSI 2"
	T	ANSI 3"
	U	ANSI 4"
	T()	Other flange types
9.Thermistor	V	Pt100, B level
	W	Pt100, A level
	X	Pt1000, B level
	Y	Pt1000, A level
10.Rod diameter	A	3mm
	B	4mm
	C	5mm
	D	6mm
	E	8mm
	F	10mm

DB12-Selection composition

Selection example
 Flange connection type **DB12** **B** **S** **G** **L** **V** **B** **G** **N** **V** **D** **G** **X** **F** **N**

11.Rod length(mm)	G	50
	O	100
	P	150
	Q	200
	R	250
	S	300
	T	350
	U	400
	V	450
	W	500
T()	Other lengths	
12.Probe rod material	X	304SS
	Y	316/316L (1.4401/1.4435)
	Z	Other materials
13.Temperature range (°C)	A	-50...+250
	B	-50...+450
	C	-200...+250
	D	-200...+450
	E	-200...+600
	F	0...+400
	G	0...+500
T()	Other measured temperatures	
14.Safety certification	X	Intrinsic safety
	Y	Flameproof
	Z	There is no
15.Additional order information	V	Additional information
	N	There is no

Instructions:

It means that the DB12 thermal resistance is a thermometer with flanged sleeve, the connection mode is 20592 standard flange, the probe rod design is fixed installation, the connection box is stainless steel, the electrical interface is M20*1.5, the sensor is ceramic connecting block, the single three-wire system, the flange specification is DN25, the thermal resistance element is Pt100, the class B, the diameter of the probe rod is 6mm. The length of the rod is 50mm, the material of the rod is 304SS, and the temperature range is 0... 400°C, no explosion-proof, 15 items are not required.

Product certification

Compliance and approval; Rodwig thermometers meet key standards and certifications for process measurement technology; Thus guaranteeing the highest reliability in such Settings;