

The selection is detailed on page 4



A41

Diaphragm Type Pressure Gauge

Working principle

Diaphragm pressure gauge by diaphragm isolator and universal pressure gauge composed of a system pressure gauge, through the special equipment to pump the spring tube into a vacuum, and filled with flushing liquid, with the diaphragm seal diaphragm, when the pressure of the measured medium P acting on the diaphragm, so that deformation, compression system internal filled with working liquid, so that the working liquid form a P equivalent to ΔP . With the help of the conduction of the working fluid, the free end of the elastic element (spring tube) in the pressure instrument produces a corresponding elastic deformation-displacement, and then displays the measured pressure value according to the corresponding working principle of the pressure instrument.

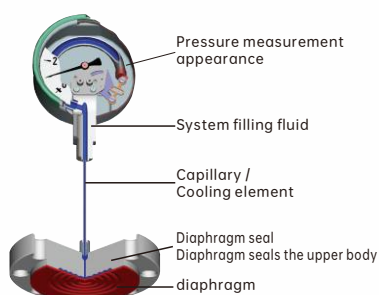

Product description

Diaphragm pressure gauge is more suitable for low pressure range. Small pressure ranges can be reliably measured through the large work surface of the circular corrugated diaphragm element.

Model A41 diaphragm pressure gauges comply with EN 837-3. The high quality design is particularly suitable for the chemical and petrochemical industry, the oil and gas industry, and energy engineering.

Stainless steel case and liquid parts meet the high requirements of anti-erosion value. For particularly high corrosion resistance requirements, the pressure chamber of the diaphragm gauge can optionally be designed using a variety of special materials such as PTFE, tantalum or Hastelloy.

For the measurement of high viscosity, crystalline or contaminated media, open connection flanges are recommended. The advantage of the open connection flange over the threaded connection is that the pressure port is not blocked, and the pressure chamber can be cleaned easily through the additional flush connection on the open connection flange.

Measurement systems with diaphragm elements, based on the design concept that the diaphragm can support itself on the flange, provide good overvoltage protection. As standard, the model A41 diaphragm pressure gauge provides overload safety up to 5 times the full scale value. As an option, higher overload safety can be achieved.

Product application

It is used to measure the pressure of heavy overload

The case filled with liquid can be used in the case of high power pulse and vibration

Suitable for liquids and gases, media with high viscosity or solid particles, and even corrosive environments

Process industries: chemicals, electric power, mining, environmental technology, construction machinery and buildings

Functional characteristics

Stainless steel housing and liquid parts

A variety of special materials are available

Can be used in combination with electrical contacts and transmission

All stainless steel construction

Measuring range 0... 40MPa



© 400-860-9760

Technical parameter

Design	Meets the EN837-3 standard
Standard size (mm)	150
Precision class	1.0
	1.6
Range	0... 400mbar to 0... 40MPa
Pressure limit	
▪ Static pressure	full-scale
▪ Dynamic pressure	0.9x full scale value
Overvoltage safety	5x full scale, Max. 40bar
Allowable temperature	
▪ Environment	- 20... 60 °C
▪ Medium	Max. +100°C
Temperature effect	When the temperature of the measuring system fluctuates around the reference temperature (+20°C), the maximum change is $\pm 0.8\%/10K$ of the range
Class of protection	IP54, according to EN 60529/IEC 60529 (liquid filled, IP65)
Connection material	304SS/316L stainless steel
Process connection and lower flange	G1/2B (external thread), SW 22
Pressure element	$\leq 0.025\text{MPa}$: 316L stainless steel
	$> 0.025\text{MPa}$: Nickel chromium alloy
Diaphragm seal ring	FPM/FKM
Drive movement	Stainless steel
Dial plate	Aluminum, white background, black print
Pointer	Adjustable reference pointer
	Aluminum, black
Housing and upper flange	Stainless steel with back relief port
	Liquid filled instrument with compensating valve vent
Watch glass	Multilayer safety glass
Mosaic ring	Bayonet ring, CRNI-stainless steel
Filling solution	Glycerin 86.5%
Optional parameter	The liquid parts are sprayed or covered with special materials such as: PTEE coating (model), Hastelloy B, Hastelloy C, Monel, nickel, titanium, silver
	Process connections from DN15 to DN80, according to DIN or ASME standards
	Ambient temperature -40... At +60°C, use silicone oil to fill the liquid
	Other process connection
	Single and double scale optional

Size mm

Normal form

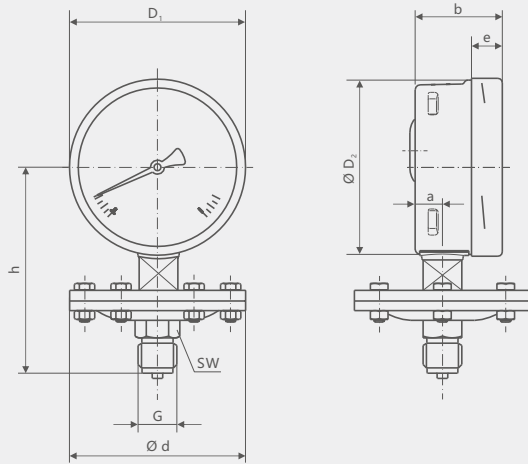

NS	Pressure range (MPa)	Size mm									weight kg
		d	a	b	D1	D2	e	G	h±2	SW	
150	> 0.025	160	15.5	49.5	161	159	17.5	G1/2B	149	22	2.90

Range table

Negative pressure	code	MPa	code	Bar	code	kPa	code	kg/cm ²	code	Psi/-inHg
		MV001	-0.1/0	BV001	-1/0	KV001	-100/0	GV001	-1/0	RV030
	code	MPa	code	Bar	code	kPa	code	kg/cm ²	code	Psi/-inHg
	MC006	-0.1/0.06	BC006	-1/0.6	KC006	-100/60	GC006	-1/0.6	PC015	-30"/0/15
	MC015	-0.1/0.15	BC015	-1/1.5	KC015	-100/150	GC015	-1/1.5	PC030	-30"/0/30
	MC030	-0.1/0.3	BC030	-1/3	KC030	-100/300	GC030	-1/3	PC060	-30"/0/60
	MC050	-0.1/0.5	BC050	-1/5	KC050	-100/500	GC050	-1/5	PC100	-30"/0/100
	MC090	-0.1/0.9	BC090	-1/9	KC090	-100/900	GC090	-1/9	PC160	-30"/0/160
	MC150	-0.1/1.5	BC150	-1/15	KC150	-100/1500	GC150	-1/15	PC200	-30"/0/200
	MC240	-0.1/2.4	BC240	-1/24	KC240	-100/2400	GC240	-1/24	PC300	-30"/0/300
Positive pressure	code	MPa	code	Bar	code	kPa	code	kg/cm ²	code	Psi
	MP001	0/0.1	Bp001	0/1	KP001	0/100	Gp001	0/1	PP1E5	0/15
	MP1E6	0/0.16	BP1E6	0/1.6	KP1E6	0/160	GP1E6	0/1.6	PP003	0/30
	MP2E5	0/0.25	BP2E5	0/2.5	KP2E5	0/250	GP2E5	0/2.5	PP006	0/60
	MP004	0/0.4	BP004	0/4	KP004	0/400	GP004	0/4	PP010	0/100
	MP006	0/0.6	BP006	0/6	KP006	0/600	GP006	0/6	PP016	0/160
	MP010	0/1	BP010	0/10	KP010	0/1000	GP010	0/10	PP020	0/200
	MP016	0/1.6	BP016	0/16	KP016	0/1600	GP016	0/16	PP030	0/300
	MP025	0/2.5	BP025	0/25	KP025	0/2500	GP025	0/25	PP040	0/400
MP040	0/4	BP040	0/40	KP040	0/4000	GP040	0/40	PP060	0/600	

A41-Selection composition

Selection example **A41**

1	A	2	B	3	E	4	MP006	5	N	6	P	7	R	8	B	9	S
---	---	---	---	---	---	---	-------	---	---	---	---	---	---	---	---	---	---

1.Dial diameter mm	A	150
2.Precision class	B	1.0
	C	1.6
3.liquid-filled	D	glycerin
	E	Silicone oil
	N	without
4.Measuring range	-	See range table (page 3)
5.Second range unit	G	MPa
	H	bar
	I	KPa
	J	kg/cm ²
	K	Psi
	N	without
6.Threaded connection (Flange connection not optional)	P	1/2NPT
	Q	M20*1.5
	R	M27*2
	S	G1/2B
	T()	Other connections
6.1.Flange connection (Threaded connection not optional)	U	DN15
	V	DN20
	W	DN25
	X	DN32
	Y	DN40
	Z	DN50
	E	DN65
	F	DN80
T()	Other specifications	
8.Installation mode	R	Radial direction
9.Watch glass	A	PC plastic
	B	Safety glass
10.material	S	304SS
	L	316L
	H	hastelloy
	N	Tantalum diaphragm
	M	Monel alloy
	P	PTFE
T()	Other materials	

A41-Selection composition

Selection example **A41**

A / B / E / MP006 / N / P / R / B / S

11.Special requirements	X	degrease
	Y	Oxygen application ≤160bar
	Z	without
12.Certificate	A	2.1Measurement report
	B	3.7Inspection certificate
	N	without
13.Additional description	Z	There are
	N	without

Instructions:

It indicates that A45 pressure gauge dial diameter is 100mm, accuracy level is 1.0%, shockproof filled silicone oil, measuring range is 0~0.6MPa, no second measuring range unit, process connection 1/2NPT(6.6.1 is one of the two options), radial installation, safety glass, body material is 304SS. Item 11/12/13 of the above table is not required.



Product Certification

Compliance and approval; Rodewig pressure meets key standards and certifications for process measurement technology; Thus guaranteeing the highest reliability in such Settings;