

The selection is detailed on page 8



LW-PB

Industry Standard Pressure Transmitter

Working principle

The working medium pressure is transmitted through the standard process connector and then affects the internal pressure sensor element. Internal electronics convert raw transmitter signals into filtered, amplified, temperature compensated and standardized signals such as 4... 20mA signal, etc. The output signal is transmitted to the next unit for signal processing via standardized connectors or cables.

Product description

The LW-PB pressure transmitter for industrial applications is the ideal solution for users with high measurement requirements.

With very good accuracy, this type of transmitter is not only rugged but also available in a variety of versions to meet a variety of application requirements. Available from 0... 0.01 to 0... 100MPa measuring range, support for all common pressure units.

These measuring ranges can be combined in almost any way with all standard industrial output signals, international process connectors, and various electrical interfaces.

In addition, the transmitter model offers a variety of options, such as different accuracy levels, extended temperature ranges, and customized pin assignments.

With a durable design, the quality is excellent and works well even in the harshest environmental conditions. This type of transmitter can meet all application requirements, whether in extreme cold conditions outdoors, in the severe shock and vibration environment of the machinery industry, or in corrosive media in the chemical industry.

Product application

Machine building
shipbuilding
Measurement and control technology
Hydraulic and pneumatic technology
Pumps and compressors

Functional characteristics

Measuring range: 0... 0.005 to 0... 100 MPa
Accuracy: 0.25% BFSL or 0.5%BFSL
Output: 4... 20mA, DC 0... 10V, DC 0... 5V etc
Electrical connections: Hertsman connectors type A and C, M12*1 round aviation connectors, 2 m long cable straight out
Process connector: G $\frac{1}{4}$ A DIN3852-E, $\frac{1}{4}$ NPT, etc

Working principle diagram

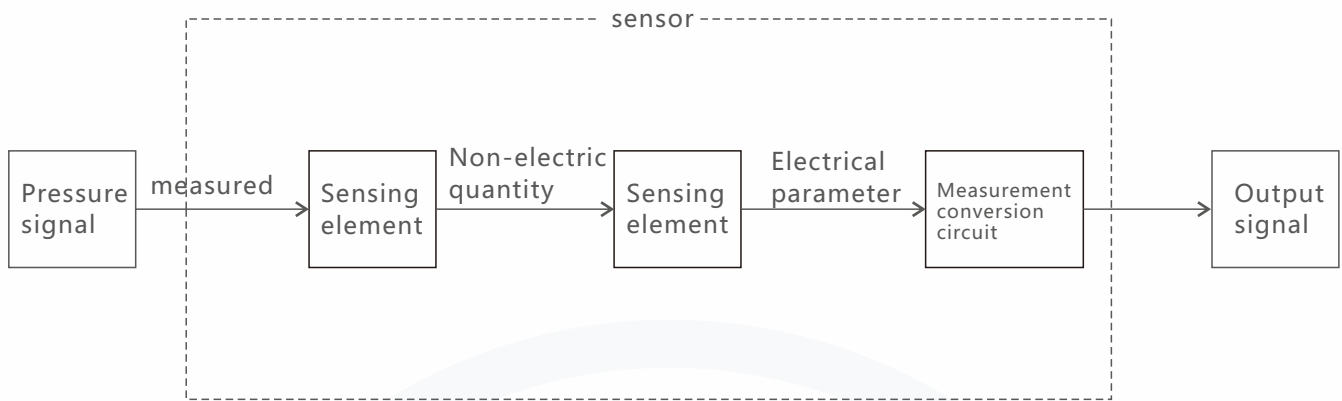

Technical parameter

Range range	See range table
Precision class	0.25%
	0.5%
Pressure limit	Not more than 1000bar
Allowable temperature	
▪ Medium temperature	-25...125°C
▪ Ambient temperature	-25...85°C
▪ Storage temperature	-40...85°C
Process connection	G1/4B
Output signal	4-20mA [Two-wire system]
Diaphragm seal ring	FPM/FKM
material	
▪ shell	304SS
▪ Pressure connection	304SS
Power supply	DC 8...32V [Two-wire system]
Current input	4...20mA < 25mA
Electronic protection	Short-circuit prevention
Degree of protection of electronic connections	Connectors and junction boxes comply with ISO 4400 (DIN 43650-A), IP65
load	$R_{max} = [(U_B - U_B \min) / 0.02A] \Omega$ [Two-wire system]
Dynamic response characteristic	Response time < 1ms
Temperature effect	When the temperature of the measuring system fluctuates around the reference temperature (+20 ° C), the maximum change is $\pm 0.2\%$ /10K of the range

Measuring range

Relative pressure								
MPa	Measuring range	0 ... 0.01	0 ... 0.016	0 ... 0.025	0 ... 0.04	0 ... 0.06	0 ... 0.1	0 ... 0.16
	Upper overvoltage limit	0.1	0.15	0.2	0.2	0.4	0.5	1
	Measuring range	0 ... 0.25	0 ... 0.4	0 ... 0.6	0 ... 1	0 ... 1.6	0 ... 2.5	0 ... 4
	Upper overvoltage limit	1	1.7	3.5	3.5	8	5	8
	Measuring range	0 ... 6	0 ... 10	0 ... 16	0 ... 25	0 ... 40	0 ... 60	0 ... 100
	Upper overvoltage limit	12	20	32	50	80	120	150
psi	Measuring range	0 ... 5	0 ... 10	0 ... 15	0 ... 20	0 ... 25	0 ... 30	0 ... 50
	Upper overvoltage limit	29	29	72.5	145	145	145	240
	Measuring range	0 ... 60	0 ... 100	0 ... 150	0 ... 160	0 ... 170	0 ... 200	0 ... 250
	Upper overvoltage limit	240	500	500	1,160	1,160	1,160	1,160
	Measuring range	0 ... 300	0 ... 400	0 ... 500	0 ... 600	0 ... 750	0 ... 800	0 ... 1,000
	Upper overvoltage limit	1,160	1,160	1,160	1,160	1,740	1,740	1,740
	Measuring range	0 ... 1,500	0 ... 2,000	0 ... 2,000	0 ... 3,000	0 ... 4,000	0 ... 5,000	0 ... 6,000
	Upper overvoltage limit	2,900	4,600	4,600	7,200	7,200	11,600	11,600
	Measuring range	0 ... 7,500	0 ... 8,000	0 ... 10,000	0 ... 15,000	-	-	-
	Upper overvoltage limit	17,400	17,400	17,400	21,700	-	-	-
Absolute pressure								
MPa	Measuring range	0 ... 0.025	0 ... 0.04	0 ... 0.06	0 ... 0.1	0 ... 0.16	0 ... 0.25	0 ... 0.4
	Upper overvoltage limit	0.2	0.2	0.4	0.5	1	1	1.7
	Measuring range	0 ... 0.6	0 ... 1	0 ... 1.6	0 ... 2.5	0.08 ... 0.12	-	-
	Upper overvoltage limit	35	35	80	80	5	-	-
psi	Measuring range	0 ... 15	0 ... 25	0 ... 50	0 ... 100	0 ... 250	-	-
	Upper overvoltage limit	72.5	145	240	500	1,160	-	-
Vacuum and +/- measuring range								
MPa	Measuring range	-0.06 ... 0	-0.04 ... 0	-0.205 ... 0	-0.016 ... 0	-0.01 ... 0	-	-
	Upper overvoltage limit	0.4	0.2	0.2	0.15	0.1	-	-
	Measuring range	-0.1 ... 0	-0.1 ... +0.06	-0.1 ... +0.15	-0.1 ... +0.3	-0.1 ... +0.5	-	-
	Upper overvoltage limit	0.5	1	1	1.7	3.5	-	-
	Measuring range	-0.1 ... +0.9	-0.1 ... +1.5	-0.1 ... +2.4	-	-	-	-
	Upper overvoltage limit	3.5	8	5	-	-	-	-
psi	Measuring range	-15 inHg ... 0	-30 inHg ... 0	-30 inHg ... +15	-30 inHg ... +30	-30 inHg ... +60	-	-
	Upper overvoltage limit	72.5	72.5	145	240	240	-	-
	Measuring range	-30 inHg ... +100	-30 inHg ... +160	-30 inHg ... +200	-30 inHg ... +300	-	-	-
	Upper overvoltage limit	500	1,160	1,160	1,160	-	-	-

The measurement ranges in the table also support kg/cm² and bar units.
Other measuring ranges are available on request.

Working condition

Allowable temperature range	Standard	selectable
medium	-30 ... +100°C [-22 ... +212°F]	-40 ... +125°C [-40 ... +257°F]
environment	-20 ... +80°C [-4 ... +176°F]	-20 ... +80°C [-4 ... +176°F]
store	-40 ... +100°C [-40 ... +212°F]	-40 ... +100°C [-40 ... +212°F]

Process connection

Standard	Thread size
EN 837	G ¼ B
	G ½ B
DIN EN ISO 1179-2	G ¼ A ¹⁾
-	G ¼ Female thread
ANSI/ASME B1.20.1	¼ NPT
	½ NPT
SAE J514 E	7/16-20 UNF with 74° taper
-	M20 x 1.5
-	G ½ male thread/G ¼ female thread
ISO 7	R ¼

1) Maximum overpressure: 60 MPa [8,700 psi]

Other process connections are available on request

Electrical connection

Connection type	Class of protection	Cable cross-sectional area	Cable diameter	Cable length
Hersman joint DIN 175301-803 A	IP65	Max. 1.5mm ²	6 ... 8mm	-
Hersman connection DIN 175301-803 with ½ NPT	IP65	Max. 1.5mm ²	-	-
Round aviation joint M12 x 1 (4 pins)	IP67	-	-	-
Bayonet connector (6 pins)	IP67	-	-	-
½NPT external threaded conduit with cable straight out	-	3 x 0.5mm ²	6.8 mm	1.5m, 3m, 5m, 10m, 5ft,10 feet, 20 feet, 30 feet, other lengths Available on request
	-			
	-			
The cable runs straight out				
▪ Standard configuration	IP67	3 x 0.5mm ²	6.8 mm	1.5m, 3m, 5m, 10m, 5ft,10 feet, 20 feet, 30 feet, other lengths Available on request
▪ non-tunable	IP68 ¹⁾	3 x 0.5mm ²	6.8 mm	
▪ tunable	IP68 ¹⁾	3 x 0.5mm ²	6.8 mm	

1) 72小时/30 kPa [4.4 psi]

Short-circuit resistance	Polarity reverse protection	Overvoltage protection	Insulation voltage
S+ vs. U-	U+ vs. U-	DC 36 V	DC 500 V

material

Material (liquid parts)	
▪ Measuring range ≤ 2.5 MPa [≤ 400 psi]	316Ti
▪ Measuring range > 2.5 MPa [> 400 psi]	316Ti and S13800
Material (non-liquid parts)	
▪ shell	316Ti
▪ Internal pressure transfer medium	Measuring range ≤ 2.5 MPa [≤ 400 psi]: Synthetic oil Measuring range > 2.5 MPa [> 400 psi]: Dry measuring unit
▪ Clamp nut	PA
▪ Hersman joint	PA
▪ O-ring on clamp nut	NBR
▪ Plain washer	VMQ

Wiring diagram

DIN 175301-803 A Hersman joint			
		Two-wire system	Three-wire system
	U+	1	1
	U-	2	2
	S+	-	3

Bayonet connector (6 pins)			
		Two-wire system	Three-wire system
	U+	brown	brown
	U-	blue	blue
	S+	-	black

Hersman connection DIN 175301-803 with 1/2 NPT			
		Two-wire system	Three-wire system
	U+	1	1
	U-	2	2
	S+	-	3

1/2 NPT external threaded conduit with cable straight out			
		Two-wire system	Three-wire system
	U _B	brown	brown
	0V	blue	blue
	S+	-	black

M12 x 1 (4 pin) round aviation joint			
		Two-wire system	Three-wire system
	U+	1	1
	U-	3	3
	S+	-	4

The cable runs straight out			
		Two-wire system	Three-wire system
	U+	brown	brown
	U-	green	aluminium
	S+	-	white
	shield	gray	gray

Size mm

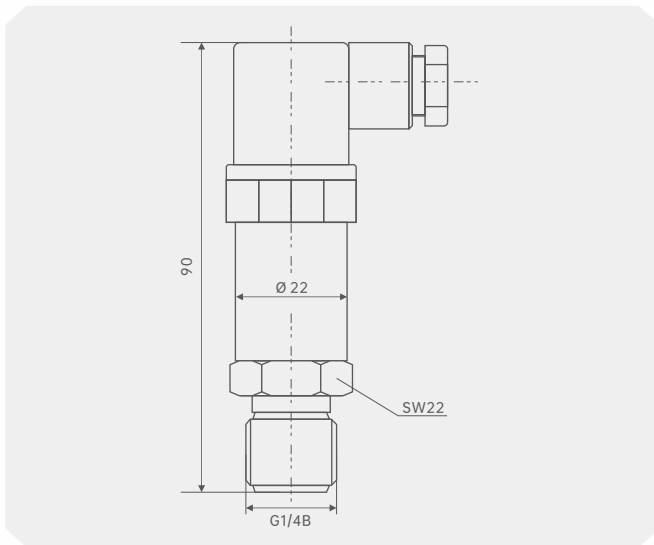

Process connection

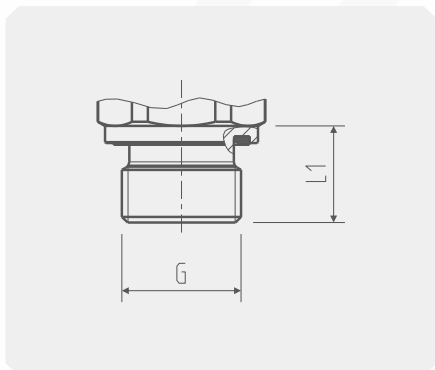

G	L1
G1/4A	12

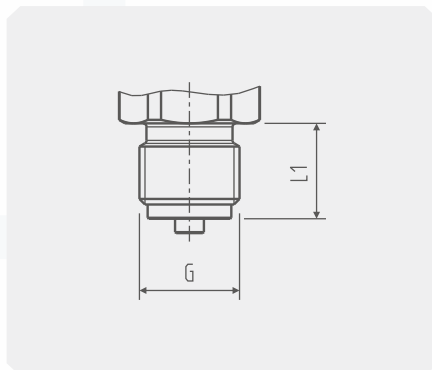

G	L1
G1/4B	13
G1/2B	20
M20*1.5	20

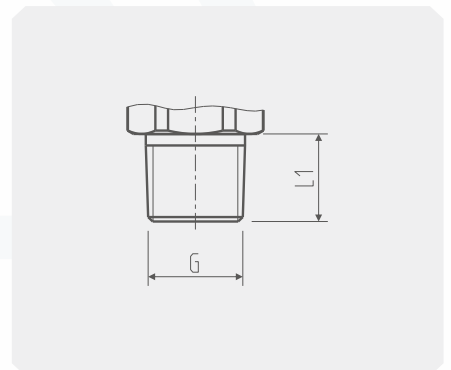

G	L1
1/4NPT	13
1/2NPT	19
R1/4	13

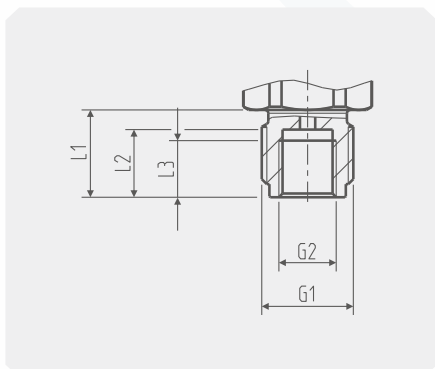

G	G2	L1	L2	L3
G1/4A	G1/4	20	15.5	13

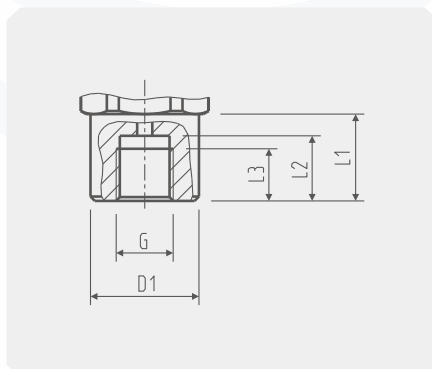

G	D1	L1	L2	L3
G1/4 internal thread	25	20	15	12

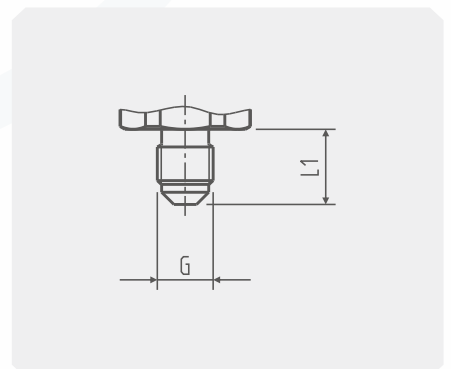

G	L3
7/16-20 UNF, With 74° taper	12

Range table

Negative pressure	code	MPa	code	Bar	code	kPa	code	kg/cm ²	code	Psi/-inHg
	MV001	-0.1/0	BV001	-1/0	KV001	-100/0	GV001	-1/0	RV030	-30"/0 Hg
Positive and negative pressure	code	MPa	code	Bar	code	kPa	code	kg/cm ²	code	Psi/-inHg
	MC006	-0.1/0.06	BC006	-1/0.6	KC006	-100/60	GC006	-1/0.6	PC015	-30"/0/15
	MC015	-0.1/0.15	BC015	-1/1.5	KC015	-100/150	GC015	-1/1.5	PC030	-30"/0/30
	MC030	-0.1/0.3	BC030	-1/3	KC030	-100/300	GC030	-1/3	PC060	-30"/0/60
	MC050	-0.1/0.5	BC050	-1/5	KC050	-100/500	GC050	-1/5	PC100	-30"/0/100
	MC090	-0.1/0.9	BC090	-1/9	KC090	-100/900	GC090	-1/9	PC160	-30"/0/160
	MC150	-0.1/1.5	BC150	-1/15	KC150	-100/1500	GC150	-1/15	PC200	-30"/0/200
	MC240	-0.1/2.4	BC240	-1/24	KC240	-100/2400	GC240	-1/24	PC300	-30"/0/300
Positive pressure	code	MPa	code	Bar	code	kPa	code	kg/cm ²	code	Psi
	MP001	0/0.1	BP001	0/1	KP001	0/100	GP001	0/1	PP1E5	0/15
	MP1E6	0/0.16	BP1E6	0/1.6	KP1E6	0/160	GP1E6	0/1.6	PP003	0/30
	MP2E5	0/0.25	BP2E5	0/2.5	KP2E5	0/250	GP2E5	0/2.5	PP006	0/60
	MP004	0/0.4	BP004	0/4	KP004	0/400	GP004	0/4	PP010	0/100
	MP006	0/0.6	BP006	0/6	KP006	0/600	GP006	0/6	PP016	0/160
	MP010	0/1	BP010	0/10	KP010	0/1000	GP010	0/10	PP020	0/200
	MP016	0/1.6	BP016	0/16	KP016	0/1600	GP016	0/16	PP030	0/300
	MP025	0/2.5	BP025	0/25	KP025	0/2500	GP025	0/25	PP040	0/400
	MP040	0/4	BP040	0/40	KP040	0/4000	GP040	0/40	PP060	0/600
	MP060	0/6	BP060	0/60	KP060	0/6000	GP060	0/60	PP100	0/1000
	MP100	0/10	BP100	0/100	KP100	0/10000	GP100	0/100	PP150	0/1500
	MP160	0/16	BP160	0/160	KP160	0/16000	GP160	0/160	PP200	0/2000
	MP250	0/25	BP250	0/250	KP250	0/25000	GP250	0/250	PP300	0/3000
	MP400	0/40	BP400	0/400	KP400	0/40000	GP400	0/400	PP400	0/4000
	MP600	0/60	BP600	0/600	KP600	0/60000	GP600	0/600	PP600	0/6000
MP1000	0/100	BP1000	0/1000	KP1000	0/100000	GP1000	0/1000	PP1000	0/10000	

LW-PB-Selection composition

Selection example LW-PB

MP001 / A / B / E / G / S / U / Y / G

1.Measuring range	R()	See range table (page 7)
2.Output signal	A	4-20mA
3.Power supply	B	DC 8-32V
4.Temperature range	E	0...80°C
	F	-30...100°C
5.Precision class	G	0.5%
	H	0.25%
6.Process connection	N	1/2NPT
	O	1/4NPT
	P	M14*1.5
	Q	M20*1.5
	R	M27*2
	S	G1/2B
	T	G1/4B
	T()	Other connection specifications
7.Seal material	U	fluororubber
	V	Red copper
	T()	Other materials
8.Electrical connection	X	M12*1 (Circular aviation joint)
	Y	Hersman joint
	Z	Head outlet(2-5m)
9.Liquid material	G	304SS
	H	316L
	T()	Other materials

Instructions:

LW-PB industrial standard pressure transmitter, measuring range: 0~0.1MPa, output signal 4-20mA, 24V power supply, temperature range is 0... 80°C, accuracy class 0.5%, process connection G1/2B, sealing material is fluoro rubber, electrical connection is Hersman joint, liquid material 304SS.

Product Certification

Compliance and approval; Rodewieg pressure gauges meet key standards and certifications for process measurement technology; Thus guaranteeing the highest reliability in such Settings;