

[The selection is detailed on page 7](#)



CT17

Universal Temperature Controller

Working principle

Through the temperature sensor, the ambient temperature is automatically sampled and monitored in real time. When the ambient temperature is higher than the control setting value, the control circuit starts and the control return difference can be set. If the temperature is still rising, when it rises to the set alarm temperature point, start the alarm function. When the controlled temperature can not be effectively controlled, in order to prevent the damage of the equipment, it can also stop the equipment from continuing to run through the function of tripping.

Product application

Factory and industrial furnace construction
Process engineering
Plastics technology and processing
Ventilation and air conditioning
General industrial application

Product description

The compact universal controller of the CT17 series provides display, control and monitoring of temperature.

The controller has multifunctional inputs, which means that the configuration of the sensor inputs can be set. It also means that the flexibility of the controller is greatly increased, and warehousing is easier. Alarm output for monitoring actual values can also be used as standard values.

Control parameters can be set in a wide range. Automatic adjustment helps to find the best control parameters that can be activated. The monitoring output can be set as a relay (slow control), as a logic level status relay that controls the electronic entity (for fast control and high current load), or as a continuous 4... 20 mA output.

As an option, there is a second alarm output that can be used to monitor the actual value and control loop, and a heater burn out alarm that can be used to monitor the output, or a second monitor output. RS-485 serial interface is also possible.

Functional characteristics

Control mode, configurable (PID, PI, P, PD, ON/OFF)

Integrated automatic adjustment

Optional monitoring output - relay, logic level or 4... 20 mA

Multifunctional input for Pt100, thermocouples and standard industrial signals

Available in 3 sizes of case



Technical parameter

reveal	
Actual value	7-segment LED 5-bit red
Set point	7-segment LED, 5-digit, green
Adaptive range	-2000... 10000
input	
▪ Quantity and type	1 multifunctional input for resistance thermometers, thermocouples and standard signals
▪ Input configuration	Selection is available via terminal connection and menu-driven programming
▪ Resistance thermometer	Pt100, JPt100, 3-wire, maximum allowable resistance per connection wire: 10Ω
Thermoelectric couple	
▪ Type K, J, R, S, E, T, N, PL-II, C (W / Re5-26)	Maximum allowable external resistance: 100Ω
▪ Btype	Maximum allowable external resistance: 40Ω
Standard Signal (DC)	
▪ 0 ... 20 mA, 4 ... 20 mA	Input impedance 50Ω
▪ 0 ... 1 V	Input impedance > 1MΩ
▪ 0 ... 5 V, 1 ... 5 V, 0 ... 10 V	Input impedance > 100kΩ
Measuring time	125ms
Power source	AC 100 ... 240 V, 50 ... 60 Hz
	AC/DC 24 V
Monitor output	
Monitor Output 1 (O1)	There could be 3 different versions
Relay contact	Load: AC 250 V, 3 A (resistive load), AC 250 V, 1 A (inductive load, $\cos \phi = 0.4$)
Logic level	DC 0... Max. 12 V 40 mA (short circuit proof) for controlling electronic switching relays (solid state relays, SSR)
Analog current signal	4... 20 mA, maximum load 550Ω
Control mode	PID, PI, PD, P, ON/OFF (configurable)
	To determine the control parameters of the PID control, you can activate automatic tuning.
Scale range	Thermocouple, resistance thermometer without decimal point: 0 to input range limit
	Thermocouple, resistance thermometer with decimal point: 0.0 to input range limit
	Standard signal: 0.0... 1,000.0%
Integration time	0... 3,600 s
Differential time	0... 1,800 s
cycle	1... 120 s (not suitable for analog current signal monitoring output)
hysteresis	Available only in on/off control mode
	Thermocouple and resistance thermometer: 0.1... 1000.0 versus °C
	Standard signal: 1... 1,000 (the input scale is one decimal place and is taken over by hysteresis).
Alarm Output 1 (EV1)	
Alarm type	For actual value monitoring, delay and time delay can be selected from 24 alarm types and can be configured
Switch type	ON/OFF
Relay contact	Load: AC 250 V, 3 A (resistive load), AC 250 V, 1 A (inductive load, $\cos \phi = 0.4$, switching period: Max. 100,000)

Technical parameters - Optional function

Set point input (EV1, 2 points)	When parameter memory is selected, set points can be stored between SV1 and SV4
	Set point: 2 o'clock
	Short circuit: about 16mA
Alarm Output 2 (EV2)	As for Alarm Output 1 (EV1)
Heater break alarm	Monitor the heating current using a current transformer (CT, included in the delivery)
	Rated current: 20A, 100A (specify when ordering!)
	Phase 1: Detects overheating through CT1 input
	Three-phase: Detects overheating through CT1 and CT2 inputs
Adjustment accuracy: within 5% of the rated value	
Monitoring Output 2 (O2)	For three-point control
exportation	Logic level: DC 12 V± 15%, Max 40 mA (short circuit proof) for controlling electronic switching relays (solid state relays, SSR)
	Analog current signal: DC 4... 20 mA, maximum load 550Ω
Scale range	Monitor output 1 with a ratio of 0.0 to 10.0 times
Integration time	Same integration time as monitoring output 1
Differential time	Same differentiation time as monitoring output 1
cycle	0.5 s or 1... 120 s
Overlapping tape/dead tape	Thermocouple and resistance thermometer: -200.0... + 200.0 °C
	Standard signal: -2000... +2000 (the input scale is one decimal place and is taken over by hysteresis)
hysteresis	Available only in on/off control mode
	Thermocouple and resistance thermometer: 0.1... 1000.0 °C
	Standard signal: 1... 10000 (The input scale is one decimal place and is taken over by hysteresis)
Heat dissipation mode	Air cooling (linear process, standard setting)
	Oil cooling (1.5 times the slope of the linear process)
	Water cooling (twice the slope of a linear process)
Serial interface	RS-485
	Transfer rate can be set (9,600 bps, 19,200 bps or 38,400 bps)
Isolation Voltage output (P24)	Output voltage: DC 24 V, 30 mA
	Ripple voltage: within 200 mV
	Maximum load current: DC 30 mA
Environmental condition	
▪ Ambient temperature	0... 50 °C (32... 122 °F)
▪ Storage temperature	- Twenty... +50 °C
▪ humidity	Thirty-five... 85% relative humidity, no condensation
Comply with IEC 61010-1 environmental conditions	Class II overvoltage, contamination level 2
shell	
Materials	Polycarbonate fiber
colour	black
Class of protection	Front: IP66, back: IP00 (according to IEC 60529 / EN 60529)
weight	
▪ Model CT17-S	110g
▪ Model CT17-H	160g
▪ Model CT17-L	220g
Install	Screw type mounting bracket with wall thickness of 1 to 15 mm

Input type table

Input signal	Measuring range		Measurement error of span, in %	
			Standard	Exceptional case
Current signal	°C	°F		
DC 0 ... 10 mA	-1,999 ... 1,999 °C	-3,566.2 ... 3,630.2 °F	±0.2 %±1 digit	-
DC 0 ... 20 mA	-1,999 ... 1,999 °C	-3,566.2 ... 3,630.2 °F	±0.2 %±1 digit	-
DC 4 ... 20 mA	-1,999 ... 1,999 °C	-3,566.2 ... 3,630.2 °F	±0.2 %±1 digit	-
DC 0 ... 10 mA Root of a root	-1,999 ... 1,999 °C	-3,566.2 ... 3,630.2 °F	±0.2 %±1 digit	-
DC 4 ... 20 mA Root of a root	-1,999 ... 1,999 °C	-3,566.2 ... 3,630.2 °F	±0.2 %±1 digit	-
Voltage signal				
DC 0 ... 20mV	-1,999 ... 1,999 °C	-3,566.2 ... 3,630.2 °F	±0.2 %±1 digit	-
DC 0 ... 40mV	-1,999 ... 1,999 °C	-3,566.2 ... 3,630.2 °F	±0.2 %±1 digit	-
DC 0 ... 100mV	-1,999 ... 1,999 °C	-3,566.2 ... 3,630.2 °F	±0.2 %±1 digit	-
DC -20 ... 20mV	-1,999 ... 1,999 °C	-3,566.2 ... 3,630.2 °F	±0.2 %±1 digit	-
DC -100 ... 100mV	-1,999 ... 1,999 °C	-3,566.2 ... 3,630.2 °F	±0.2 %±1 digit	-
DC 0 ... 5V	-1,999 ... 1,999 °C	-3,566.2 ... 3,630.2 °F	±0.2 %±1 digit	-
DC 1 ... 5V	-1,999 ... 1,999 °C	-3,566.2 ... 3,630.2 °F	±0.2 %±1 digit	-
DC -5 ... 5V	-1,999 ... 1,999 °C	-3,566.2 ... 3,630.2 °F	±0.2 %±1 digit	-
DC 0 ... 10V	-1,999 ... 1,999 °C	-3,566.2 ... 3,630.2 °F	±0.2 %±1 digit	-
DC 0 ... 5V Root of a root	-1,999 ... 1,999 °C	-3,566.2 ... 3,630.2 °F	±0.2 %±1 digit	-
Thermoelectric couple				
Thermocouple B	400 ... 1,800 °C	752 ... 3,272 °F	±0.2 %±1 digit	≤0°C: +0.4 %±1 digit
Thermocouple S	0 ... 1,600 °C	32 ... 2,912 °F	±0.2 %±1 digit	≤0°C: +0.4 %±1 digit
Thermocouple K	0 ... 1,300 °C	32 ... 2,372 °F	±0.2 %±1 digit	≤0°C: +0.4 %±1 digit
Thermocouple E	0 ... 1,000 °C	32 ... 1,832 °F	±0.2 %±1 digit	-
Thermocouple T	-200 ... +400 °C	-328 ... +752 °F	±0.2 %±1 digit	-
Thermocouple J	0 ... 1,200 °C	32 ... 2,192 °F	±0.2 %±1 digit	-
Thermocouple R	0 ... 1,600 °C	32 ... 2,912 °F	±0.2 %±1 digit	≤0°C: +0.4 %±1 digit
Thermocouple N	0 ... 1,300 °C	32 ... 2,372 °F	±0.2 %±1 digit	≤0°C: +0.4 %±1 digit
Thermocouple F2	700 ... 2,000 °C	1,292 ... 3,632 °F	±0.2 %±1 digit	≤0°C: +0.4 %±1 digit
Thermocouple Wre3-25	0 ... 2,300 °C	32 ... 4,172 °F	±0.2 %±1 digit	-
Thermocouple Wre5-26	0 ... 2,300 °C	32 ... 4,172 °F	±0.2 %±1 digit	-
Thermal resistance				
Thermal resistance Cu50	-50 ... +150 °C	-58 ... +302 °F	±0.1 %±1 digit	-
Thermal resistance Cu53	-50 ... +150 °C	-58 ... +302 °F	±0.1 %±1 digit	-
Thermal resistance Cu100	-50 ... +150 °C	-58 ... +302 °F	+0.1 %±1 digit	-
Thermal resistance Pt100	-200 ... +650 °C	-328 ... +1,202 °F	+0.1 %±1 digit	-

Size mm

Model number CT17-S

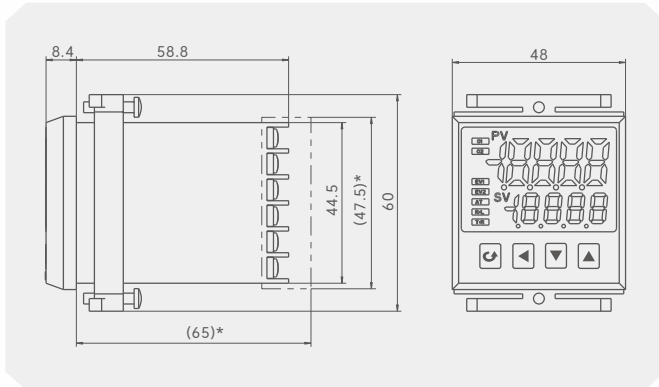

Panel opening

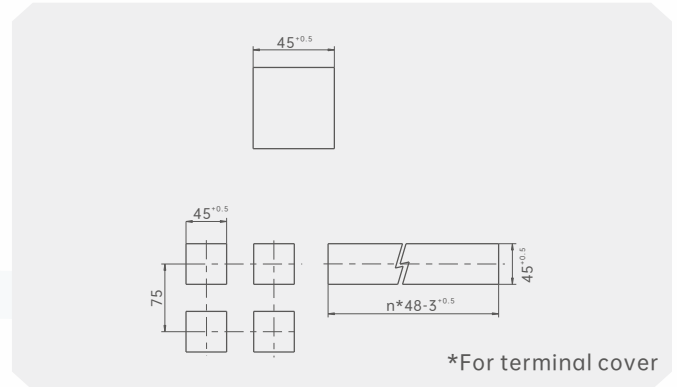

Model number CT17-H

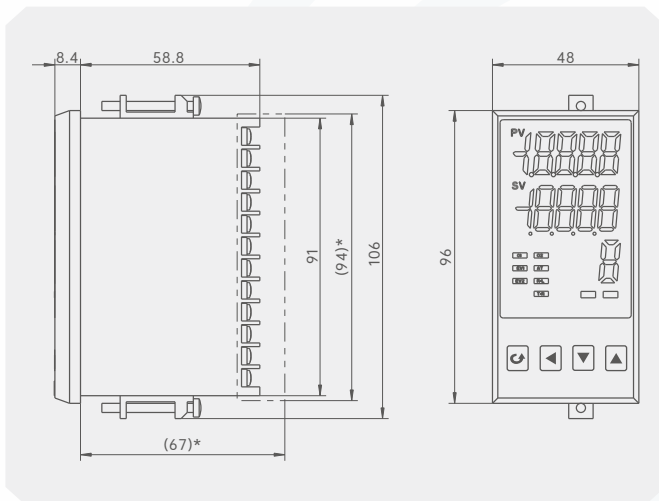

Panel opening

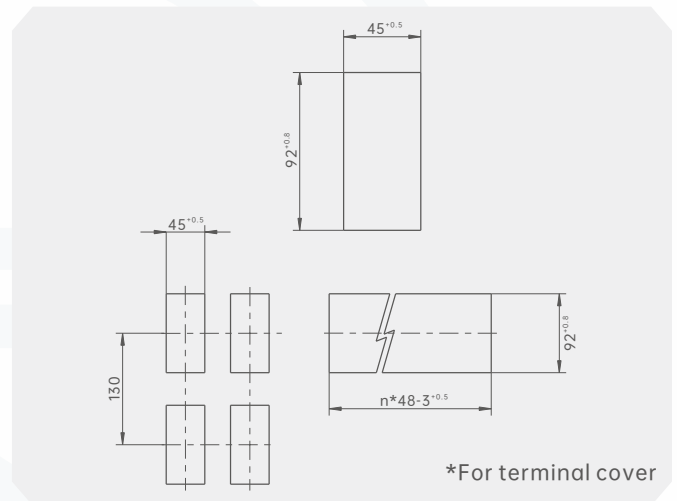

Model number CT17-L

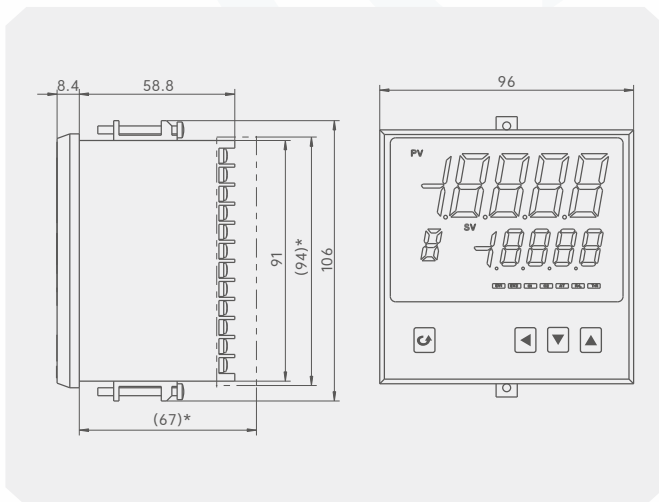

Panel opening

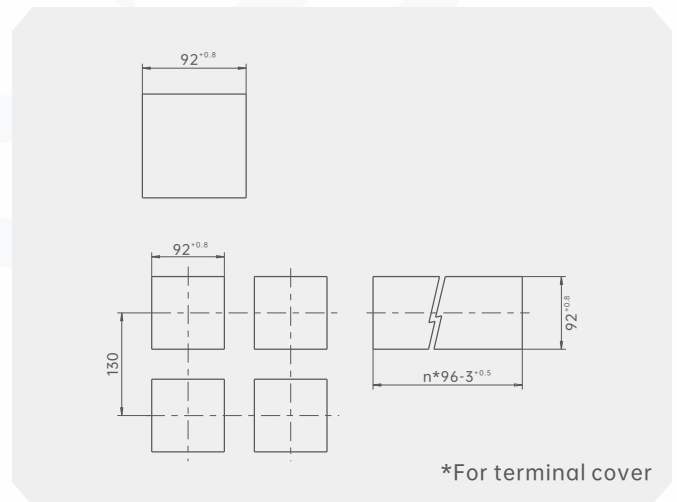

Connecting terminal

Model number CT17-S

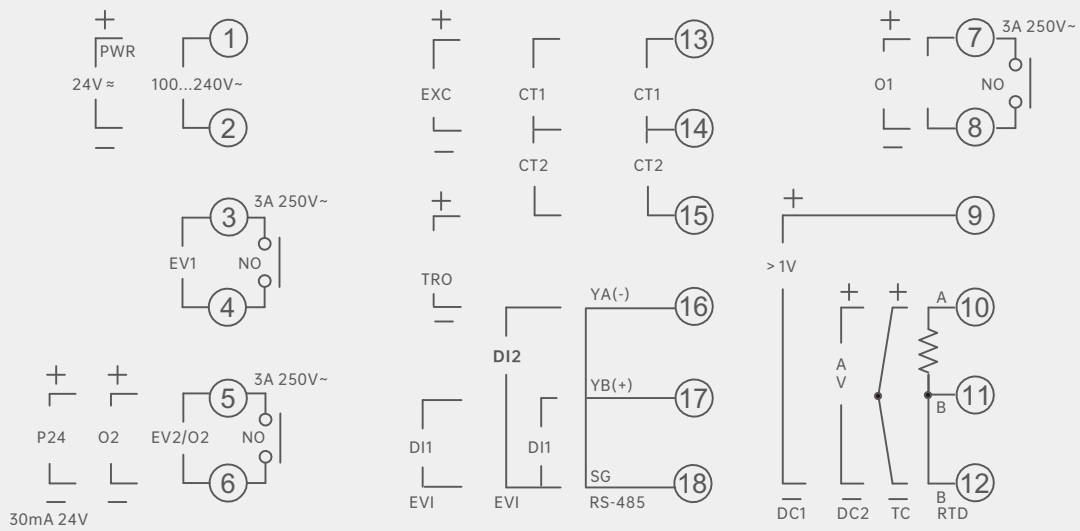

Model number CT17-H, CT17-L

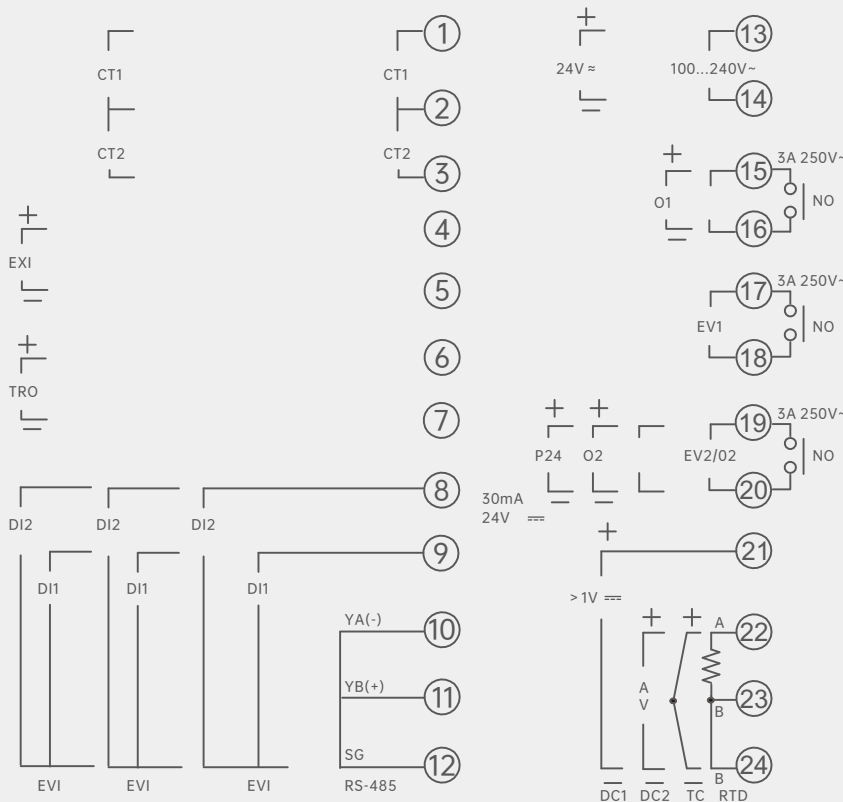

Instructions:

- PWR Power source
- EV1 Alarm output 1
- EV2 Alarm output 2
- O1 Monitor output 1
- O2 Monitor output 2
- P24 Isolated voltage output, DC 24 V, 30 mA
- TC Thermocouple input
- RTD Resistance thermometer input
- CT1 CT input 1
- CT2 CT input 2
- RS-485 Serial interface RS-485
- EVI Set value Enter DI1 / DI2
- EXC External regulatory input
- TRO Analog output
- DC1 Dc input 0... 5V or 0... 10V
- DC2 Dc input 0... 1V, 0... 20mA or 4... 20mA

CT17-Selection composition

Selection example **CT17**

1	S	2	G	3	M	4	4-20	5	P	6	A	7	N	8	S
---	---	---	---	---	---	---	------	---	---	---	---	---	---	---	---

1.Selection description	S	CT17-S	
	H	CT17-H	
	L	CT17-L	
2.Overall dimension	A	160×80×110mm	
	B	80×160×110mm	
	C	96×96×110mm	
	D	96×48×110mm	
	E	48×96×110mm	
	F	72×72×110mm	
	G	48×48×105mm	
	H	160×80×110mm (Lighted column)	
	I	80×160×110mm (Lighted column)	
3.Working power supply	L	220V AC	
	M	24V DC	
4.Input (all the way)	T ()	See Input type table (page 4)	
5.Control output	N	0-10mA	
	O	0-20mA	
	P	4-20mA	
	Q	0-5V	
	R	1-5V	
	S	0-10V	
	Z	Relay contact output	
	U	Single-phase thyristor zero-crossing trigger pulse	
	V	Solid state relay drives voltage output	
	W	Bidirectional control silicon on off output	
	X	Three-phase thyristor zero trigger pulse output	
Y	no-output		
6.Converter output	A	0-10mA	
	B	0-20mA	
	C	4-20mA	
	D	0-5V	
	E	1-5V	
	F	0-10V	
	G	no-output	
7.Alarm output	N	1Circuit relay output	
	O	2Circuit relay output	
	P	3Circuit relay output	
	Q	4Circuit relay output	



CT17-Selection composition

Selection example **CT17** **S** **G** **M** **4-20** **P** **A** **N** **S**

1 2 3 4 5 6 7 8

8.Communication output	R	RS-232 communication
	S	RS-485 communication
	V	RS-232 print
	U	no-output

Instructions:

It indicates that the overall size of CT17-S temperature universal controller is 48×48×105mm, the power supply is 24V DC, one input is 4-20mA, the control output is 4-20mA, the transmission output is 0-10V, the alarm output is 1 relay output, and the RS-485 communication output.



Product Certification

Compliance and approval; Rodewig pressure gauges meet key standards and certifications for process measurement technology; Thus guaranteeing the highest reliability in such Settings;