

The selection is detailed on page 5



A65

100mm Standard Diaphragm Table

Working principle

A65 type bellow pressure gauge mainly relies on the bellow as an induction element to measure the pressure. The outside of the bellow is welded with a connecting rod and connected to the gear movement. When the gas pressure is transferred to the bellow, the wall of the bellow will deform and change with the change of pressure. The measured value is indicated on the dial by a pointer fixed on the gear shaft.

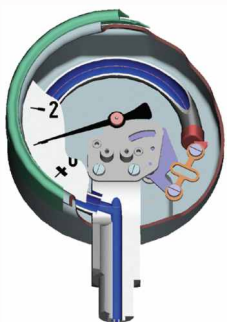

Product description

The A65 Diaphragm gauge is a proven gauge for diaphragm measuring systems. The diaphragm measurement principle is particularly suitable for low pressure conditions.

When pressurized, the diaphragm element expands in proportion to the incident pressure, and the expansion signal is transmitted to the movement and displayed on the dial.

The case and bayonet ring are stainless steel. The process connector is 304 stainless steel. The modular design ensures a wide range of case materials, process connections, dial sizes and range combinations. Therefore, the product can be widely used in various industrial applications.

If mounted on the control panel, the diaphragm gauge can be fixed with surface mounting flanges, triangular frames or mounting brackets, depending on the type of process connection.

Product application

Measure the pressure of a dry, corrosive or ambient corrosive gas medium

With a liquid-filled housing, it can be used in applications with high dynamic pressure pulses or vibrations

Process industries: chemical, petrochemical, pharmaceutical, biotechnology, machinery and power generation industries

Functional characteristics

Zero correction from front

304SS/316L all stainless steel construction

Special pressure interface positions are available on request

Measuring range: 0... 60KPa

Technical parameter

Design	Meets the EN837-3 standard
Standard size (mm)	100
Precision class	1.0
	1.6
Range	0... 0.6KPa to 0... 60KPa
Pressure limit	
▪ Static pressure	full-scale
▪ Dynamic pressure	0.9x full scale value
Allowable temperature	
▪ Environment	- 20... 60 °C
▪ Medium	Max. +100°C
Temperature effect	When the temperature of the measuring system fluctuates around the reference temperature (+20 °C), the maximum change is $\pm 0.6\%$ /10K of the range
Class of protection	IP54, compliant with EN 60529/IEC 60529 (liquid filled, IP 65)
Connection material	316L stainless steel
Installation mode	Radial or axial
Process connection	NS 100, G1/2B (external thread), SW 22
Pressure element	316L stainless steel
Diaphragm seal ring	FPM/FKM
Drive movement	Stainless steel
Zero adjustment	There are bolts on the front
Dial plate	Aluminum, white background, black print
	Adjustable reference pointer
Pointer	Aluminum, black
Shell	CrNi- stainless steel
Watch glass	Multilayer safety glass
Mosaic ring	Bayonet ring, CRNI-stainless steel
Filling solution	Glycerin 86.5%
Optional parameter	Allowable ambient temperature -40... +60°C (filled with silicone oil)
	Panel or surface mounting flange
	Other process connection

Size mm

Radial connection

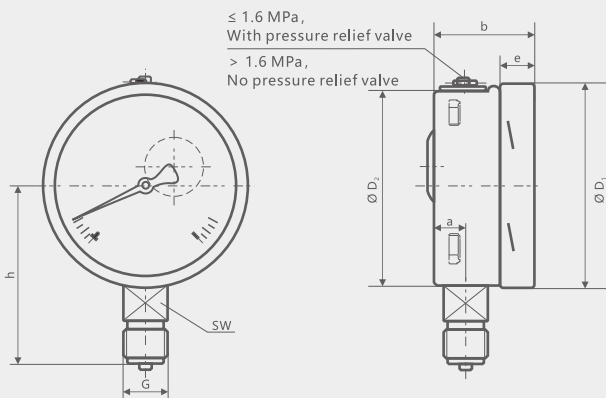

Axial center mounting

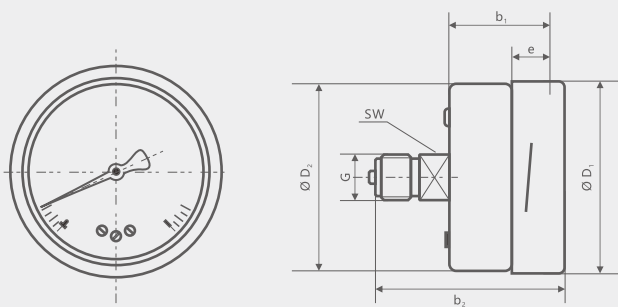

Axial eccentric installation

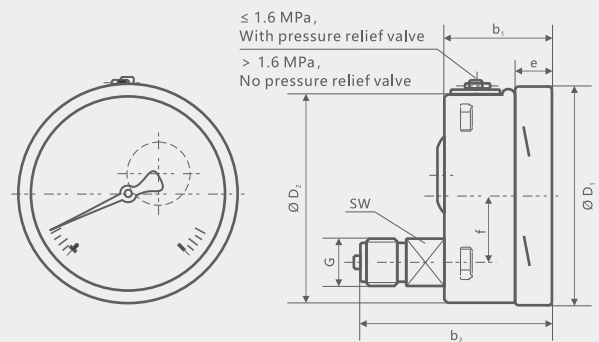

NS	Size mm												weight kg
	a	b	b1	b2	D1	D2	e	f	G	h±1	x	SW	
100	15.5	49.5	49.5	83	101	99	17.5	30	G1/2B	87	37	22	1.10

Range table

Positive Pressure	Code	Kpa	Code	Pa
	KP001	0/1	YP160	0/160
	KP1E6	0/1.6	YP250	0/250
	KP2E5	0/2.5	YP400	0/400
	KP004	0/4	YP600	0/600
	KP006	0/6		
	KP010	0/10		
	KP016	0/16		
	KP025	0/25		
	KP040	0/40		
	KP060	0/60		

Positive and negative pressure	Code	Kpa	Code	Pa
	KC8E8	-0.8/0.8	YC080	-80/80
	KC1E2	-1.2/1.2	YC120	-120/120
	KC002	-2/2	YC200	-200/200
	KC003	-3/3	YC500	-500/500
	KC005	-5/5		
	KC008	-8/8		
	KC012	-12/12		
	KC020	-20/20		

Negative pressure	Code	Kpa	Code	Pa
	KV001	-1/0	YV160	-160/0
	KV1E6	-1.6/0	YV250	-250/0
	KV2E5	-2.5/0	YV400	-400/0
	KV004	-4/0	YV600	-600/0
	KV006	-6/0		
	KV010	-10/0		
	KV016	-16/0		
	KV025	-25/0		
	KV040	-40/0		
	KV060	-60/0		



A65-Selection composition

Selection example **A65** A B F KP006 N Q U B S

1.Dial diameter mm	A	100
2.Precision class	B	1.0
	C	1.6
3.liquid-filled	E	Glycerin
	F	Silicone oil
	N	without
4.Measuring range	-	See range table (page 3)
5.Second range unit	G	MPa
	H	bar
	I	KPa
	J	kg/cm ²
	K	Psi
	N	without
6.Threaded connection (Flange connection not optional)	P	1/2NPT
	Q	M20*1.5
	R	M27*2
	S	G1/2B
	T ()	Other connections
6.1.Flange connection (Threaded connection not optional)	U	DN15
	V	DN20
	W	DN25
	X	DN32
	Y	DN40
	Z	DN50
	E	DN65
	F	DN80
	T ()	Other specifications
	7.Installation mode	U
V		Axial direction
W		Shaft forward edging (three-hole mounting)
X		Radial front edge (three-hole mounting)
Y		The shaft is mounted on the rear bracket
8.Watch glass	A	PC plastic
	B	Safety glass
9.material	S	PC plastic
	L	Safety glass

A65-Selection composition

Selection example **A65** A B F KP006 N Q U B S

10.Special requirements	X	Degrease
	Y	Oxygen application ≤160bar
	Z	without
11.certificate	A	2.1 Measurement report
	B	3.7 Inspection certificate
	N	without
12.Additional description	Z	There are
	N	without

Instructions:

It indicates that the dial diameter of A65 pressure gauge is 100mm, the accuracy level is 1.0%, the shock-resistant silicone oil, the measuring range is 0~6.0kPa, there is no second measuring range unit, the process connection M20*1.5, the radial installation, the safety glass, the body material is 304SS. Items 10/11/12 in the above table are not required

Product Certification

Compliance and approval; Rodewig pressure gauges meet key standards and certifications for process measurement technology; Thus guaranteeing the highest reliability in such Settings;