

Please refer to page 13 for selection details



FE10-E

Electromagnetic flowmeter (wireless type)

Product description

The electromagnetic flow converter is paired with different types of electromagnetic flow sensors to form an electromagnetic flow meter system. Used to measure the volumetric flow rate of conductive fluid in a closed pipeline. Widely applicable to flow measurement and control of production processes in industries such as petrochemicals, steel metallurgy, water supply and drainage, irrigation, water treatment, total control of environmental wastewater, papermaking, pharmaceuticals, food, and other agricultural sectors; Suitable for measuring the total amount of conductive liquids.

This battery powered integrated converter can be matched with ordinary electromagnetic flowmeter sensors and achieve flow measurement accuracy of level 1 and level 0.5. That is to say, simply connecting the original ordinary electromagnetic flowmeter sensor with this battery powered converter, the user has developed a battery powered electromagnetic flowmeter.

This battery powered converter comes standard with a conventional battery pack and can work continuously for 3-6 years. If equipped with a high-capacity lithium battery pack, the continuous working time will be longer.

Scope of application

The wireless pressure transmitter adopts wireless transmission technology, which does not require wiring and is easy to install, suitable for pressure monitoring scenarios in multiple industries. Widely used in fields such as petrochemicals, municipal water supply and drainage, gas pipelines, HVAC, water conservancy and water management, and sewage treatment. It can be used for real-time pressure collection and remote monitoring of pipeline pressure, tank containers, hydraulic and pneumatic equipment, boiler pressure vessels, mining pipeline networks, and building water supply systems. It is also suitable for working conditions such as unmanned operation in the field, scattered measurement points, and complex wiring difficulties, achieving wireless data upload and assisting in intelligent monitoring, safe operation and maintenance, and digital management.

Features

- Programmable low-frequency rectangular wave excitation improves the stability of flow measurement and reduces power loss;
- Adopting a 32-bit embedded microprocessor, the computing speed is fast. High precision;
- All digital processing, strong anti-interference ability, reliable measurement, high accuracy, and a flow measurement range of up to 1000:1;
- 12V~36V DC power supply, 36~240V AC power supply, dual power supply, suitable for different on-site working conditions, Chinese and English menu operation, easy to use, simple to operate, easy to learn and understand;
- High definition backlit LCD display;
- It has bidirectional flow measurement, bidirectional total accumulation function, current and frequency output function;
- There are three integrators inside that can display forward cumulative quantity, reverse cumulative quantity, and differential cumulative quantity respectively;
- Equipped with conductivity measurement function, it can distinguish whether the sensor is empty or not;
- Constant current excitation, with a wide current range, can be used in conjunction with different companies and types of electromagnetic flow sensors;
- Equipped with self checking and self diagnostic functions;
- Using SMD devices and surface mount technology, the circuit has high reliability.



Technical parameter

Main power supply	AC220V 50Hz /DC24V/3.6V
Power consumption	<15W(Power consumption matched with sensor)
Display and buttons	Chinese and English display, which can display instantaneous flow maximum, cumulative flow and alarm display (excitation open circuit alarm, air traffic control alarm, flow overrun alarm). 4 thin film touch switches for data setting.
counter	Positive total amount, Reverse Total
output signal	
▪ Analog Output	Two way, fully isolated 0~10mA/4~20mA load resistance: 0~10mA time, 0~1.5KΩ; 4~20mA time, 0~750Ω
▪ Frequency output	The upper limit of output frequency can be set between 1-5000Hz for both forward and reverse flow outputs. Transistor with photoelectric isolation Open collector bidirectional output. External power supply Not greater than 35V, the maximum current of the collector during conduction is 50mA.
▪ Alarm output	Two channels of transistor Open collector alarm output with photoelectric isolation. The external power supply should not exceed 35V, and the maximum current of the collector during conduction is 250mA. Alarm status: fluid empty pipe, excitation disconnection, flow exceeding limit.
▪ Pulse output	Forward and reverse flow output, with an output pulse upper limit of up to 5000CP/S. The maximum pulse is 0.0001~1.0m ³ /P. The pulse width is automatically set to 20ms or Square wave. The transistor with photoelectric isolation Open collector output. The external power supply should not exceed 35V, and the maximum current of the collector during conduction is 50mA
Matching accuracy	± 0.5% of the indicated value, optional ± 0.3% or ± 0.2% of the indicated value
Damping time constant	Continuous variables can be selected from 0 to 100 seconds (90%) for time grading
correspondence	Optional RS232C or RS485 serial communication interface, HART communication protocol, with lightning protection
Power loss	The internal design of the instrument has a non power down clock that can store 16 power down records for 10 years
the protection grades	IP65, IP66, IP67, IP68 Selectable
explosive-proof grade	Ex ia IIC T3...T6, Ex db IIC T6...T1 Gb Selectable

Chinese Intelligent Converter

Characteristics and Scope of Application

The intelligent converter for Chinese and English displays adopts a 16 bit embedded microprocessor. Fully digital quantity processing, with bidirectional flow measurement function, instantaneous flow rate, positive and negative accumulation stars, and difference accumulation quantity, used to measure the volume flow rate of conductive media such as clean water, sewage, acid, alkali, salt solution, or liquid-solid two-phase fluid.

Technical performance parameters

Nominal diameter	DN6mm ~ DN3000mm
Nominal pressure	0.6~4.0MPa (Special pressure can be customized)
accuracy	0.5% of the indicated value, and 0.3% or 0.2% of the indicated value can be selected.
Lining material	Polychloroprene rubber, polyurethane rubber, silicone rubber, polytetrafluoroethylene (PTFE), perfluoroethylene propylene (F46), PFA
Electrode form	Standard type, scraper type and replaceable type
Electrode material	SUS316.Hastelloy B, Hastelloy C, titanium, tantalum, platinum-iridium alloy, stainless steel coated with tungsten carbide.
Medium temperature	
▪ One body type	-20°C ~+70°C
▪ Splitting type	Polychloroprene/polyurethane lining (-20°C ~+60°C) PTFE lining /PFA lining /F46 lining/Polysilicone fluororubber lining (-40°C ~+180°C)
ambient temperature	-25°C ~ +60°C
Environmental humidity	5~100% RH (relative humidity)

Technical performance parameters

Dielectric conductivity	20 $\mu\text{S}/\text{cm}$
measuring range	1500: 1 Velocity setting V 15m/s
structural style	One type, sub-type, immersion type, explosion-proof type
the protection grades	IP65, IP66, IP67, IP68 Selectable
Explosion-proof sign	Ex ia IIC T3...T6, Ex db IIC T6...T1 Gb Selectable
Product standard	JB/T9248-1999 Electromagnetic flowmeter

Texture of wood

Lining material	Main performance	serviceable range
Polychloroprene rubber	1. Excellent elasticity, high breaking force and good wear resistance.	Water, sewage, weakly abrasive mud and pulp Temperature resistance range: $-20^{\circ}\text{C}\sim+60^{\circ}\text{C}$
	2. Resistant to the corrosion of ordinary low-concentration acid, alkali and salt media, and not resistant to the corrosion of oxidizing media.	
polyurethane rubber	1. Excellent wear resistance (equivalent to 10 times of natural rubber)	Neutral and highly abrasive pulp, coal slurry, mud, etc. Temperature resistance range: $-20^{\circ}\text{C}\sim+60^{\circ}\text{C}$
	2. Poor acid and alkaline resistance	
	3. It cannot be used in water mixed with organic solvents.	
Polysilicone fluororubber	1. Excellent elasticity, high breaking force and high temperature resistance.	water Temperature resistance range: $-20^{\circ}\text{C}\sim+180^{\circ}\text{C}$
	2. not resistant to any concentration of acid, alkali, salt medium corrosion.	
Polytetrafluoroethylene (PTFE)	1. A material with the most stable chemical properties in plastics can resist boiling hydrochloric acid, sulfuric acid and aqua regia, strong alkali and various organic solvents, and is not resistant to the corrosion of chlorine trioxide, high-speed liquid oxygen, liquid oxygen and ozone.	Strong corrosive media such as concentrated acid and alkali. Temperature resistance range: $-40^{\circ}\text{C}\sim+170^{\circ}\text{C}$
	2. poor wear resistance	
Polyperfluoroethylene propylene F46	1. Corrosion resistance is the same as PTFE.	Like PTFE, it can be used in low abrasion media. Temperature resistance range: $40^{\circ}\text{C}\sim+160^{\circ}\text{C}$
	2. low wear resistance	
	3. Strong negative pressure resistance.	
PFA	1. Wear resistance is the same as PTFE	Can be used in negative pressure state. Temperature resistance range: $-40^{\circ}\text{C}\sim+160^{\circ}\text{C}$
	2. Strong negative pressure resistance.	

Electrode material	Corrosion resistance
SUS316	It is used in industrial water, domestic water, sewage and weakly corrosive media, and is widely used in petroleum, chemical, steel and other industrial sectors and municipal and environmental protection fields.
Hastelloy B(HB)	It has good corrosion resistance to all concentrations of hydrochloric acid below the boiling point, and is also resistant to corrosion by non-oxidizing acids, bases and non-oxidizing solutions such as sulfuric acid, phosphoric acid, hydrofluoric acid and organic acid. Corrosion of liquid.
Hastelloy C(HC)	Resistant to corrosion of non-oxidizing acids, such as nitric acid, mixed acid or mixed medium of sulfuric acid and sulfuric acid, and also resistant to corrosion of oxidizing salts such as Fe^* , Cl or other oxidants. Such as hypochlorite solution above normal temperature and seawater corrosion.
Titanium (Ti)	Resistant to seawater, various chlorides and hypochlorite, oxidizing acids (including fuming sulfuric acid), organic acids, alkali, etc., and not resistant to pure reducing acids (such as sulfuric acid and hydrochloric acid). Corrosion. However, if the acid contains oxidants (such as nitric acid, Fe^* , Cu^{2+}), the corrosion will be greatly reduced.
TanTalum (ta)	Excellent corrosion resistance, similar to glass, resistant to almost all chemical media except hydrofluoric acid, fuming sulfuric acid and alkali (including boiling hydrochloric acid, nitric acid and Sulfuric acid and aqua regia below 150P). Note: It is not resistant to corrosion in alkali.
platinum-iridium alloy	Applicable to almost all chemicals, but not to aqua regia and Xuan salt.
Stainless steel coated tungsten carbide	Used for non-corrosive, highly abrasive media.

Note: This table is for reference only, because there are many kinds of media, and its corrosivity is influenced by complex factors such as temperature, concentration and flow rate. Users should make their own choices according to the actual situation, and if necessary, do corrosion resistance tests of the materials to be selected, such as hanging test.

Size mm

Split type

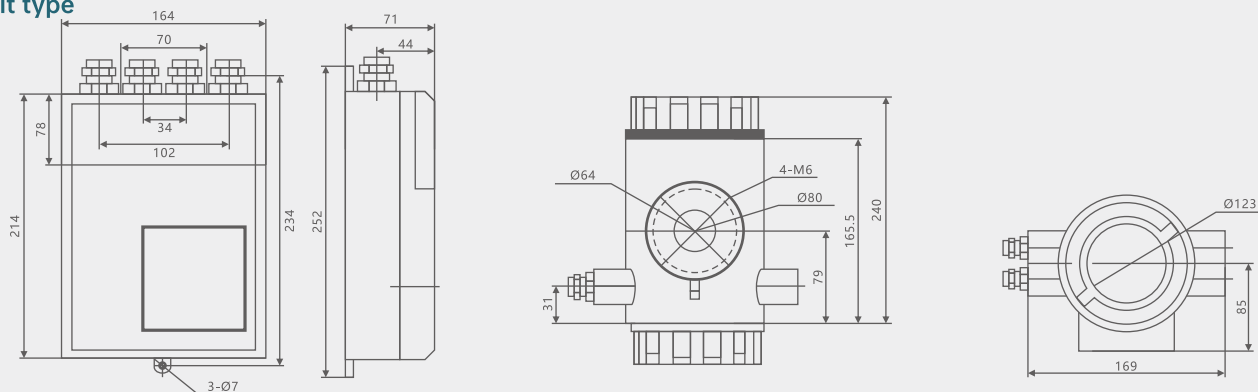

Integrated

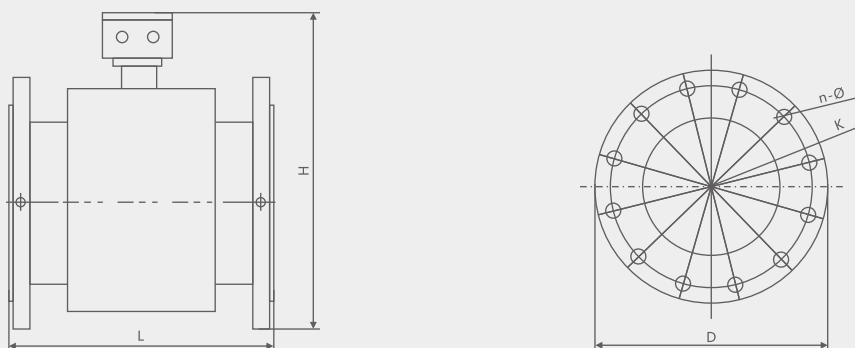

DN6mm~DN3000mm Outline drawing of flange type sensor

Nominal Diameter (mm)	nominal pressure (MPa)	Overall dimensions			Reference weight (kg)
		Instrument length L (including lining)	D	H	
6	4.0	200	90	220	6
10		200	90	220	6
15		200	95	220	8
20		200	105	220	10
25		200	115	223	12
32		200	140	240	13
40		200	150	250	14
50		200	165	263	15
65	1.6	250	185	283	18
80		250	200	290	20
100		250	235	318	25
125		250	270	350	28
150		300	300	380	30
200		350	340	430	50
250		450	405	495	70
300		500	460	547	95
350	1.0	550	520	602	120
400		600	580	665	140
450		600	640	720	160
500		600	715	783	200
500		600	715	783	200
600		600	840	897	280

Size mm

Nominal Diameter (mm)	nominal pressure (MPa)	Overall dimensions			Reference weight (kg)
		Instrument length L (including lining)	D	H	
700	1.0	700	895	982	350
800		800	1015	1092	400
900		900	1115	1192	480
1000		1000	1230	1299	550
1200	0.6	1200	1405	1488	660
1400		1400	1630	1700	750
1600		1600	1830	1924	850
1800		1800	2045	2134	980
2000		2000	2265	2344	1200
2200		2200	2475	2549	1600
2400		2400	2685	2754	2000
2600		2600	2905	2964	2400
2800		2800	2905	3169	2700
3000		3000	3315	3369	2900

Flange size

The connecting flange and installation dimensions are shown in Figure 5 and Table 5

Executive standards for connecting flanges:

4.0MPa (DN6mm~DN50mm)	GB/T9119-2000
1.6MPa (DN65mm~DN250mm)	JB/T81-94
1.0MPa (DN300mm~DN1000mm)	JB/T81-94
0.6MPa (DN1200mm~DN3000mm)	JB/T81-94

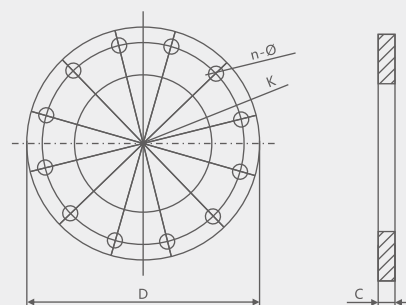

Figure 5 Connection flange diagram

Table 5

nominal pressure (bar)	Nominal Diameter (mm)	D	K	Ø	n	C
4.0	6	90	60	14	4	14
	10	90	60	14	4	14
	15	95	65	14	4	16
	20	105	75	14	4	16
	25	115	85	14	4	16
	32	135	100	18	4	18
	40	145	110	18	4	18
	50	160	125	18	4	20



Table 5

nominal pressure (bar)	Nominal Diameter(mm)	D	K	Ø	n	C
1.6	65	180	145	18	4	24
	80	195	160	18	8	24
	100	215	180	18	8	26
	125	245	210	18	8	28
	150	280	240	23	8	28
	200	335	295	23	12	30
	250	405	355	25	12	32
1.0	300	440	400	23	12	28
	350	500	460	23	16	28
	400	565	515	25	16	30
	450	615	565	25	20	30
	500	670	620	25	20	32
	600	780	725	30	20	36
	700	895	840	30	24	36
	800	1010	950	34	24	38
	900	1110	1050	34	28	42
	1000	1220	1160	34	28	44
0.6	1200	1400	1340	33	32	32
	1400	1630	1560	36	36	32
	1600	1830	1760	36	40	34
	1800	2045	1970	39	44	36
	2000	2265	2180	42	48	38
	2200	2475	2390	42	52	42
	2400	2685	2600	42	56	44
	2600	2905	2810	48	60	46
	2800	3115	3020	48	64	48
	3000	3315	3220	48	68	50

Clamping/Sanitary Technical Performance Parameters

Nominal diameter	DN6mm~DN200mm
Nominal pressure	0.6~1.6MPa
accuracy	± 0.5% of the indicated value, optional ± 0.3% or ± 0.2% of the indicated value
Medium temperature	One body type 20°C~+70°C Splitting type -20°C~+160°C
ambient temperature	25°C~+60°C
Dielectric conductivity	>20µs/cm
Lining material	Polytetrafluoroethylene (PTFE), perfluoroethylene propylene (F46)、PFA
Electrode material	SUS316、Hastelloy B, Hastelloy C, Titanium, Tantalum, Platinum and Iridium Alloys
Electrode form	Conventional electrode, detachable electrode
structural style	One-piece, sub-piece, immersion type and explosion-proof type
Protection level	IP65, IP66, IP67, IP68 Selectable
Explosion proof sign	Ex ia IIC T3...T6, Ex db IIC T6...T1 Gb Selectable

Size mm

Clamping type

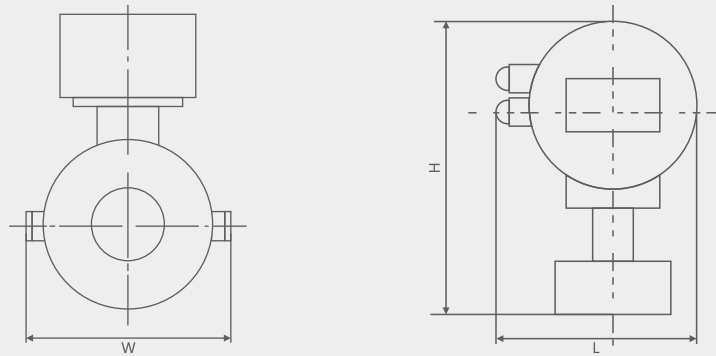

Fig. 6 Outline drawing of clamping electromagnetic flow sensor

Nominal diameter (mm)	Outline dimension (mm)			Reference weight (kg)
	H	W	L	
6	200	98	80	2.5
10	200	98	80	2.5
15	200	98	80	2.5
20	169	98	80	2.6
25	179	106	80	2.6
40	198	125	80	3.0
50	213	135	120	3.6
65	229	148	120	4.5
80	244	164	120	5.2
100	265	189	120	7.0
125	298	214	140	9.6
150	328	240	160	12.8
200	376	290	220	22.0

Size mm

Clamping type

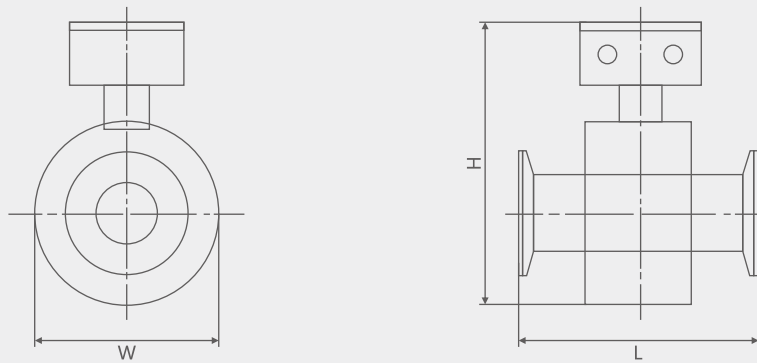

Fig. 7 Outline drawing of sanitary electromagnetic flow sensor

Nominal diameter(mm)	outline dimension(mm)			Reference weight(kg)
	H	W	L	
6	179	70	172	2.5
10	179	70	172	2.5
15	179	70	172	2.5
20	179	70	172	2.6
25	189	83	172	2.6
40	196	95	172	3.0
50	214	105	172	3.6
65	220	115	172	4.5
80	240	135	200	5.2
100	252	146	200	7.0
125	276	170	200	9.6
150	310	204	256	12.8
200	336	230	256	22.0

High pressure type

Characteristics and scope of application

High-voltage electromagnetic flow sensor adopts special lining technology, which is resistant to high pressure and negative pressure. It is specially used to measure the volume flow of conductive liquid or liquid-solid two-phase medium such as mud and cement slurry under high pressure in geological, petroleum exploration and oilfield systems.

Technical performance parameters.

Nominal diameter	DN25mm ~ DN250mm
nominal pressure	6.3MPa、10MPa、16MPa、25MPa、42MPa
precision	0.5% of the indicated value, and 0.3% or 0.2% of the indicated value can be selected.
Lining material	Polytetrafluoroethylene (PTFE), perfluoroethylene propylene (F46), PFA
Electrode material	SUS316, Hastelloy B, Hastelloy C, titanium and stainless steel are coated with tungsten carbide.
structural style	One-size and one-size
medium temperature	-10°C~+160°C
ambient temperature	-25°C~+60°C
Dielectric conductivity	20μs/cm
Explosion-proof sign	Ex ia IIC T3...T6, Ex db IIC T6...T1 Gb Selectable
attended mode	Flange type, oil union type

Size mm

Clamping type

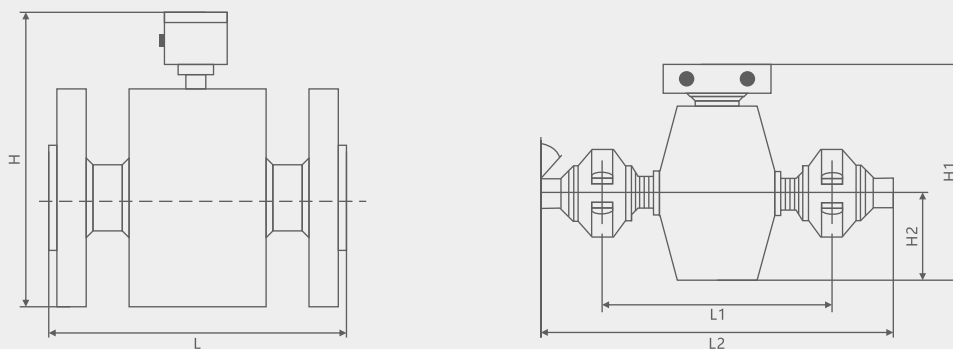

Figure 8 Outline Drawing of Flange High Pressure Sensor

Nominal Diameter (mm)	nominal pressure (MPa)	L	H
25	25	240	265
32		240	275
40		280	285
50		280	315
65		330	345
80		330	365
100		380	385
125		460	445
150		480	460
200		560	515
250		640	565

Nominal Diameter (mm)	L1	L2	H1	H2
25	460	290	340	105
40	460	290	340	105
50	460	290	340	105
65	460	290	380	140
80	490	320	380	140
100	490	320	400	156

Note: 1. Flange standard: GB/T91 15.2-20002. Different pressure levels result in corresponding changes in the overall dimensions of the instrument (listed as 25MPa in the table)3. Can also be supplied according to the diameter range required by the user



On Battery

Characteristics and Scope of Application

The battery powered electromagnetic flowmeter converter adopts internal battery power supply without the need for external power supply, and is suitable for situations where the outdoor power grid cannot reach and the power grid is difficult to lay. It is particularly suitable for monitoring, metering, and settlement of tap water supply systems.

technical performance parameters

Caliber (mm)	DN6mm~DN600mm
flange	Complies with GB9119 standard (standard configuration), carbon steel (optional stainless steel), other standards to be negotiated separately
Pressure level	1.0MPa、1.6MPa、2.5MPa、4.0MPa
Lining material	Poly (Neoprene), polyurethane rubber, polysiloxane fluororubber, polytetrachloroethylene (PTFE), polyfluoroethylene propylene (F46), PFA
conductivity	20 μ S/cm
electrode	SUSU316, Hastelloy B, Hastelloy C, titanium, tantalum, platinum iridium alloy, stainless steel coated tungsten carbide
Protection level	Ex ia IIC T3...T6, Ex db IIC T6...T1 Gb Selectable
Medium temperature	-20 $^{\circ}$ C~70 $^{\circ}$ C
ambient temperature	-25 $^{\circ}$ C~60 $^{\circ}$ C
environmental effect	< \pm 0.1 %/ior
Basic error	\pm 0.5% of the indicated value
Repeatability error	< \pm 0.25%
measuring range	< 10m/s
Electrical connections	M20X1.5 sealing sleeve, G1/2, 1/2NPT
source	Built in 2-5 batteries with a voltage of 3.6V (replaceable after battery depletion)
Battery life	More than 3 years (2 batteries with 1/5HZ response)

Plug-in

Based on Faraday's law of induction and adopting international advanced technology, the plug-in electromagnetic flowmeter is a kind of high intelligence and high reliability flow, which is widely used in the field of large diameter flow measurement due to its very high cost performance ratio.

Characteristics and Scope of Application

- The measurement accuracy is not affected by changes in liquid density, viscosity, temperature, pressure, and conductivity.
- The highly reliable plug-in installation method eliminates the need to disassemble the measuring tube for sensor installation and maintenance, making it more suitable for on-site use where water cannot be stopped. Additionally, it can be installed through openings on old pipelines.
- Simple structure and high reliability.
- The nominal diameter range is wide, suitable for all diameter pipelines between DN100 and DN3000.
- Integrated grounding electrode, achieving good grounding of instruments.
- The sensor adopts advanced processing technology, solid-state packaging, vibration resistance, penetration resistance, and long service life, making the instrument have good measurement accuracy and stability.



Technical performance parameters

Nominal diameter	DN100mm~DN3000mm
Nominal pressure	1.6MPa、2.5MPa、4.0MPa
Measurement tube material	carbon steel、SUS304
Sensor measurement head material	ABS
Electrode material	SUS316、Hastelloy B, Hastelloy C, Titanium, Tantalum
accuracy	± 1.5% for flow rate<0.5m/s. ± 1.0% for full scale flow rate>1m/s
Medium temperature	ABS: +60°C
ambient temperature	-25°C~+60°C
Relative temperature	5%~95%
atmospheric pressure	86~106KPa
Requirements for straight pipe sections	Upstream 15D, downstream 10D
Protection level	IP65, IP66, IP67, IP68 Selectable
Connection method	Flange connection, threaded connection
Explosion proof sign	Ex ia IIC T3...T6, Ex db IIC T6...T1 Gb Selectable

Appearance and installation

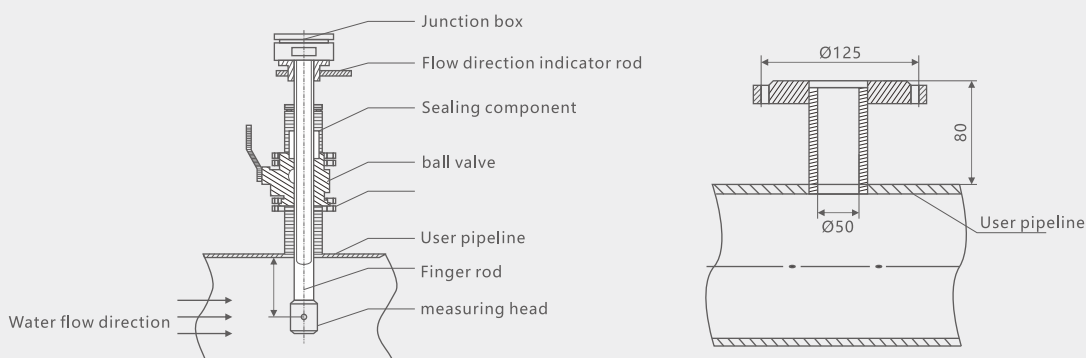

Electrical connections

Electrical connection of the transmitter with a 2-wire 4-20mA output

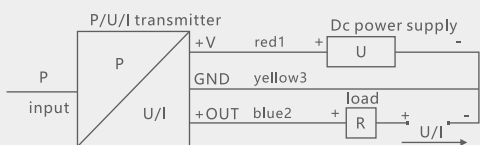
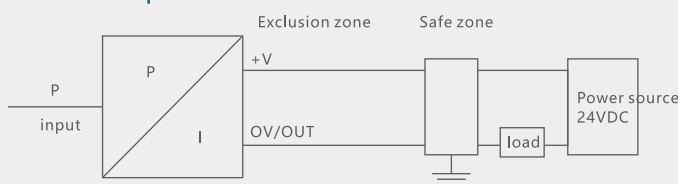
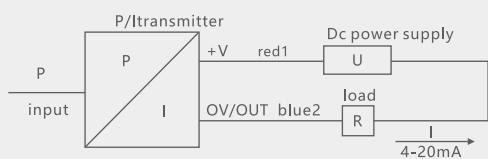

Explosion proof parameters of safety barriers

$U_i < 28VDC$ $L_i < 93mA$
 $L_i < 0.1mH$ $C_i < 0.02MF$
 $P_i < 0.65W$

Explosion proof parameters of safety barriers

$U_o < 28VDC$ $I_o < 93mA$
 $P_o < 0.65W$

Measuring caliber and flow rate comparison table

Pipe diameter	Velocity of flow						
	0.5 (m/s)	1 (m/s)	2 (m/s)	3 (m/s)	4 (m/s)	5 (m/s)	10 (m/s)
DN10	0.1414m ³ /h	0.2827m ³ /h	0.5654m ³ /h	0.8482m ³ /h	1.1308m ³ /h	1.4137m ³ /h	2.8271m ³ /h
DN15	0.3181m ³ /h	0.6362m ³ /h	1.2723m ³ /h	1.9085m ³ /h	2.5447m ³ /h	3.1808m ³ /h	6.3625m ³ /h
DN20	0.5655m ³ /h	1.1310m ³ /h	2.2619m ³ /h	3.3928m ³ /h	4.5239m ³ /h	5.6548m ³ /h	11.3103m ³ /h
DN25	0.8836m ³ /h	1.7671m ³ /h	3.5343m ³ /h	5.3014m ³ /h	7.0686m ³ /h	8.8357m ³ /h	17.6714m ³ /h
DN32	1.4476m ³ /h	2.8953m ³ /h	5.7906m ³ /h	8.6858m ³ /h	11.5812m ³ /h	14.4765m ³ /h	28.9533m ³ /h
DN40	2.2619m ³ /h	4.5238m ³ /h	9.0478m ³ /h	13.5717m ³ /h	18.0956m ³ /h	22.6195m ³ /h	45.2384m ³ /h
DN50	3.5343m ³ /h	7.0686m ³ /h	14.1372m ³ /h	21.2058m ³ /h	28.2743m ³ /h	35.3428m ³ /h	70.6862m ³ /h
DN65	5.9730m ³ /h	11.9459m ³ /h	23.8918m ³ /h	35.8377m ³ /h	47.7836m ³ /h	59.7295m ³ /h	119.4591m ³ /h
DN80	9.0478m ³ /h	18.0956m ³ /h	36.1911m ³ /h	54.2867m ³ /h	72.3823m ³ /h	92.4778m ³ /h	180.9563m ³ /h
DN100	14.1327m ³ /h	28.2743m ³ /h	56.5487m ³ /h	84.8230m ³ /h	113.0973m ³ /h	141.3717m ³ /h	282.7432m ³ /h
DN125	22.0893m ³ /h	44.1786m ³ /h	88.3573m ³ /h	132.5359m ³ /h	176.7146m ³ /h	220.8932m ³ /h	441.7861m ³ /h
DN150	31.8086m ³ /h	63.6173m ³ /h	127.2345m ³ /h	190.8515m ³ /h	254.469m ³ /h	318.086m ³ /h	636.1733m ³ /h
DN200	56.5487m ³ /h	113.0973m ³ /h	226.1947m ³ /h	339.292m ³ /h	452.389m ³ /h	565.4867m ³ /h	1130.9735m ³ /h
DN250	88,3573m ³ /h	176.7146m ³ /h	353.4292m ³ /h	530.1438m ³ /h	706.858m ³ /h	833.5728m ³ /h	1767.1464m ³ /h
DN300	127.2345m ³ /h	264.4690m ³ /h	508.938m ³ /h	763.4070m ³ /h	1017.8760m ³ /h	1272.3450m ³ /h	2544.6901m ³ /h
DN350	173.1803m ³ /h	346.3606m ³ /h	692.7212m ³ /h	1039.08180m ³ /h	1385.4424m ³ /h	1731.8030m ³ /h	3463.6063m ³ /h
DN400	226.1947m ³ /h	452.3893m ³ /h	904.7787m ³ /h	1357.1680m ³ /h	1809.5574m ³ /h	2261.9467m ³ /h	4523.8932m ³ /h
DN450	286.2776m ³ /h	572.5553m ³ /h	1145.1105m ³ /h	1717.6658m ³ /h	2290.2210m ³ /h	2862.7763m ³ /h	5725.5533m ³ /h
DN500	353.4292m ³ /h	706.8583m ³ /h	1413.71674m ³ /h	2120.5750m ³ /h	2827.4334m ³ /h	3534.2917m ³ /h	7068.5835m ³ /h
DN600	508.9380m ³ /h	1017.876m ³ /h	2035.752m ³ /h	3053.62810m ³ /h	4071.504m ³ /h	5089.3801m ³ /h	10178.7601m ³ /h
DN700	692.7212m ³ /h	1386.4424m ³ /h	2770.88474m ³ /h	4156.3271m ³ /h	5541.7694m ³ /h	6927.2118m ³ /h	13854.4242m ³ /h
DN800	904.7787m ³ /h	1809.5574m ³ /h	3619.1147m ³ /h	5428.6721m ³ /h	7238.2295m ³ /h	9047.7868m ³ /h	18095.5741m ³ /h
DN900	1145.1105m ³ /h	2290.2210m ³ /h	4580.4421m ³ /h	6870.66310m ³ /h	9047.7868m ³ /h	11451.1052m ³ /h	22902.2122m ³ /h
DN1000	1413.7167m ³ /h	2827.4334m ³ /h	5654.8668m ³ /h	8482.3002m ³ /h	11309.7336m ³ /h	14137.1669m ³ /h	28274.3344m ³ /h
DN1200	2035.7520m ³ /h	4071.5041m ³ /h	8143.0082m ³ /h	12214.5122m ³ /h	16286.0163m ³ /h	20357.5204m ³ /h	40715.04120m ³ /h
DN1400	2770.8847m ³ /h	5541.7694m ³ /h	11083.5389m ³ /h	16625.3083m ³ /h	22167.0778m ³ /h	27708.8472m ³ /h	55417.694m ³ /h
DN1600	3619.1147m ³ /h	7238.22950m ³ /h	14476.4589m ³ /h	21714.6884m ³ /h	28952.9179m ³ /h	36191.1474m ³ /h	72382.2951m ³ /h
DN1800	45804420m ³ /h	9160.8842m ³ /h	18321.7684m ³ /h	27482.6526m ³ /h	36643.5367m ³ /h	45804.420m ³ /h	91608.8423,m ³ /h
DN2000	5654.8667m ³ /h	11309.7336m ³ /h	22619.4671m ³ /h	33929.2007m ³ /h	45238.9342m ³ /h	56548.6678m ³ /h	113097.3363m ³ /h
DN2200	6842.3887m ³ /h	13684.7776m ³ /h	27369.5552m ³ /h	41054.3328m ³ /h	54739.1104m ³ /h	68423.8880m ³ /h	136847.7763m ³ /h
DN2400	8143.0080m ³ /h	16286.0163m ³ /h	32572.0326m ³ /h	48858.0490m ³ /h	65144.0653m ³ /h	81430.0816m ³ /h	162860.1631m ³ /h
DN2600	9556.7247m ³ /h	19113.4268m ³ /h	38226.8536m ³ /h	57340.2804m ³ /h	76453.7072m ³ /h	95567.1340m ³ /h	191134.2683m ³ /h
DN2800	11083.5387m ³ /h	22167.0774m ³ /h	44334.1648m ³ /h	66501.2322m ³ /h	88668.3095m ³ /h	110835.3869m ³ /h	221670.7741m ³ /h
DN3000	12723.4500m ³ /h	25446.9001m ³ /h	50893.8001m ³ /h	76340.7002m ³ /h	101787.6002m ³ /h	127234.5003m ³ /h	254469.0011m ³ /h



FE10-E-Selection and composition

Type selection example **FE10-E** **B** **H** **X** **0-60t/h** **Z** **A** **H** **N** **G** **H** **U** **A** **N**

1 2 3 4 5 6 7 8 9 10 11 12 13

1.Instrument type	A	Plug-in
	B	Integrated
	C	Split
	D	Clamp type
	E	Split insert type
	F	Split clamping type
	T ()	Other instrument types
2.Working power supply	G	communication 220VAC 50Hz(90-245VAC 50Hz)
	H	Direct current 24VDC (20-36VDC)
	I	Battery powered 3.6V
3.Output signal	N	4~20mA
	O	4~20mA、HART Protocol signal
	P	4-20mA、Switching output
	Q	4~20mA+RS485
	R	4~20mA+FF bus
	S	4~20mA+PF bus
	U	4~20mA+MODBUS bus
	W	4~20mA+RS485+MODBUS bus
	V	4~20mA+ pulse output
	X	4~20mA + 4G GPRS wireless remote transmission
	T ()	Other output signals
4.Range range	R ()	Range (Note range range)
5.Explosion-proof requirement	X	Intrinsically safe explosion protection
	Y	Flameproof
	Z	Non-explosion proof
6.Medium temperature	A	<100℃
	B	<140℃
	C	<200℃(Suitable for split type only)
	D	Other
7.Lining material	G	NE (Neoprene)
	H	PTFE (PTFE)
	I	PVC (polyvinyl chloride)
	J	PU(Polyurethane lining)
	K	PFA lining
	L	F46 lining
	M	Ceramic
T ()	Other materials	
8.Electrode material	N	316L
	O	Hastelloy C
	P	Hastelloy B
	Q	Titanium
	R	Tantalum
	S	Platinum-iridium alloy
	U	Tungsten carbide
	T ()	Other materials



FE10-E-Selection and composition

Type selection example **FE10-E** B H X 0-60t/h Z A H N G H U A N

1 2 3 4 5 6 7 8 9 10 11 12 13

9.Specification of flange connection	A	DN10
	B	DN15
	C	DN20
	D	DN25
	E	DN32
	F	DN40
	G	DN50
	H	DN65
	I	DN80
	N1	DN100
	O1	DN125
	P1	DN150
	Q1	DN200
	R1	DN250
	S1	DN300
	U	DN350
	V	DN400
	W	DN450
	X	DN500
	Y	DN600
	Z	DN700
	A1	DN800
	A2	DN900
	A3	DN1000
	A4	DN1200
	A5	DN1400
	A6	DN1600
	A7	DN1800
	A8	DN2000
	A9	DN2200
	B1	DN2400
	B2	DN2600
	B3	DN2800
	B4	DN3000
	T ()	Other specifications

FE10-E-Selection and composition

Type selection example **FE10-E** **B** **H** **X** **0-60t/h** **Z** **A** **H** **N** **G** **H** **U** **A** **N**

1 2 3 4 5 6 7 8 9 10 11 12 13

9-1.Thread connection specifications	C1	2"	
	C2	G1"	
	T()	Other connection specifications	
10.Withstand voltage level	S	PN10	
	H	PN16	
	I	PN25	
	J	PN40	
	K	PN63	
	L	PN100	
	M	Class150	
	N	Class300	
	O	Class400	
	P	Class600	
T()	Other pressure levels		
11.Body material	U	Carbon steel	
	V	304SS	
	W	316L	
	T()	Other materials	
12.Flange material	A	Carbon steel	
	B	304SS	
	C	316L	
	T()	Other materials	
13.Electrical interface	N	M20*1.5	
	O	1/2NPT	
	T()	Other	
14.Cable length	M()	(m) (for split type only)	

Instructions

The FE10-E electromagnetic flowmeter (wireless type) is integrated, with a power supply of 24VDC, output signal of 4-20mA+4G GPRS wireless remote transmission, range of 0-60t/h, no explosion-proof, medium temperature <65 °C, lining material of PTFE, electrode material of 316L, flange specification of DN50, pressure rating of 1.6MPa. The body material is carbon steel, the flange material is carbon steel, and the electrical interface is M20 * 1.5. The 14th item in the above table is a split type option.

Product Certification

Compliance and approval; LUDWIG flow meters meet key standards and certifications for process measurement technology; To ensure the highest reliability in such settings;

