

The selection is detailed on page 5



PTD-200

Intelligent Digital Display Pressure Switch

Working principle

When the pressure in the medium is higher or lower than the rated safety pressure, the disc in the sensor moves instantaneously, and the switch connector is switched on or off by connecting the guide rod. When the pressure drops to or to the rated recovery value, the disc is reset instantaneously, the switch is automatically reset, or simply when the measured pressure exceeds the rated value, the free end of the elastic element is displaced. Push the switch element directly or after comparison to change the on-off state of the switch element to achieve the purpose of controlling the measured pressure.

Product description

The PTD-200 pressure switch has an accuracy of up to 0.5% and can be freely configured with output signals (PNP/NPN, 4... 20mA/0... 10V), 5:1 scalable analog output, in addition to the PTD-200 also has excellent self-diagnosis function, can provide customers with excellent automation solutions. Flexible installation Flexible installation can be performed based on different installation environments.

There is no need to adjust the electrical interface when adjusting the display, and the display is always facing the operator. In addition, this type of pressure switch also has an M12*1 interface, which can be installed according to the cable routing requirements. During the development of the pressure switch range, Rodewig has always adhered to the concept of rugged design and selected materials suitable for machine building applications. For this reason, the housing of the electronic pressure switch and the threaded joints of the electrical connectors are made of stainless steel, making it virtually impossible to overspin or tear the connectors.

Functional characteristics

- Wide range coverage -0.1... 0 ~ 0.01... 100MPa
- All stainless steel construction
- There are various types of pressure interfaces
- 4 digit LED digital display
- The output signals come in various forms
- Intelligent digital display, page friendly, high precision, high stability, high reliability
- Reverse polarity protection and transient overcurrent and overvoltage protection

Product application

- Hydraulic and flow hydraulics
- Pneumatic device
- Plastic injection molding machinery
- General machinery manufacturing and plant construction
- Available media: compressed air, neutral and self-lubricating liquids, and neutral gases



Technical parameter

Pressure parameter	
range	-1...0~0.01...100MPa
Over duty	Double full-scale pressure or 110MPa (whichever is the smallest)
Pressure type	Gauge pressure, absolute pressure and sealed gauge pressure
Electrical parameter	
Power supply	18V~30V DC
Output signal	4mA~20mA DC/0~5V DC/0~10V DC
	Relay: NO/NC
	Transistor: NPN/PNP
Structural parameter	
shell	stainless steel
sensor	316l stainless steel
Sealing ring	viton
Electrical connection	M12*1 five-core plug
Class of protection	IP65 (plug-in type)
Environmental condition	
Medium suitability	Various liquids that are non-corrosive to 316L stainless steel and fluororubber.
Compensating temperature	-10°C~+80°C
Operating temperature	-30°C~+80°C
Storage temperature	-40°C~+125°C
Performance index	
precision	±0.1%FS (minimum) ±0.25%FS (typical) ±0.5%FS (maximum)
Zero temperature coefficient	±0.03%FS/°C (≤100KPa) ±0.02%FS/°C (> 100KPa)
Temperature coefficient of full degree	±0.03%FS/°C (≤100KPa) ±0.02%FS/°C (> 100KPa)
Long-term stability	0.03% fs/year (maximum)

Note: The accuracy includes three indexes, such as nonlinearity, repeatability and pressure hysteresis, and is calibrated on the 0.01% accuracy pressure detection equipment according to the requirements of relevant national standards.

electrical connection

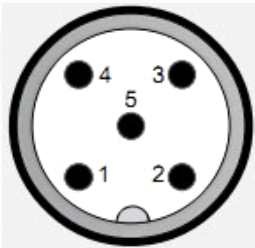
M12*1 -5P

1:VCC (brown)
2:SP2 (white)
3:GND (blue)
4:SP1 (black)
5:4~20mA (grey)

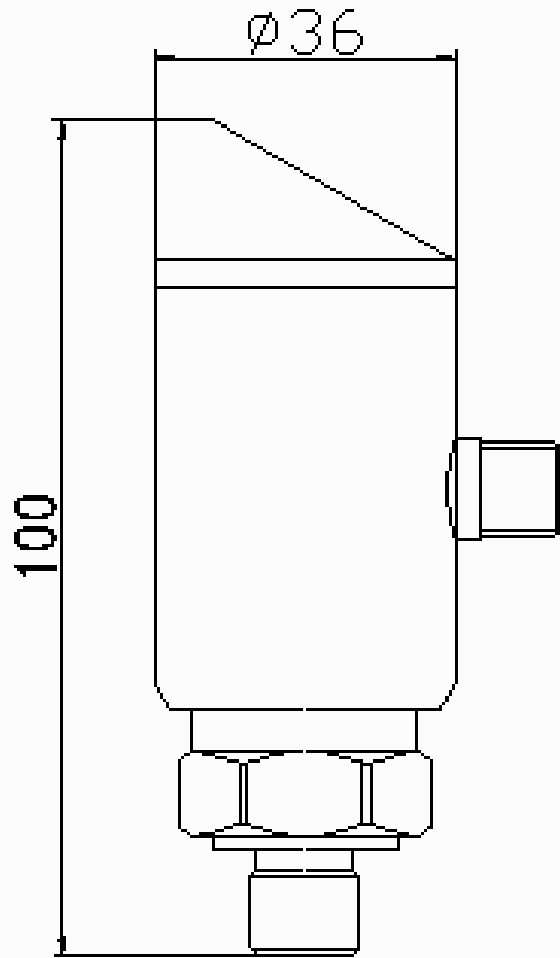

Size mm



Measuring range

Manometer pressure								
MPa	0...0.04 ¹⁾	0...0.06 ¹⁾	0...0.1 ¹⁾	0...1.6 ¹⁾	0...0.25	0...0.4	0...0.6	0...1
	0...1.6	0...2.5	0...4	0...6	0...10	0...16	0...25	0...40
	0...60	0...100	-	-	-	-	-	-
psi	0...10 ¹⁾	0...15 ¹⁾	0...25 ¹⁾	0...30 ¹⁾	0...50	0...100	0...160	0...200
	0...300	0...500	0...1,000	0...1,500	0...2,000	0...3,000	0...5,000	0...7,500

Absolute pressure								
MPa	0...0.04 ¹⁾	0...0.06 ¹⁾	0...0.1 ¹⁾	0...0.16 ¹⁾	0...0.25	0...0.4	0...0.6	0...1
	0...0.16	0...0.25	-	-	-	-	-	-
	0...60	0...100	-	-	-	-	-	-
psi	0...10 ¹⁾	0...15 ¹⁾	0...25 ¹⁾	0...30 ¹⁾	0...50	0...100	0...160	0...200
	0...300	-	-	-	-	-	-	-

Vacuum and +/-measuring range								
MPa	-0.1...0 ¹⁾	-0.1...+0.06 ¹⁾	-0.1...+0.15	0.1...+0.3	-0.1...+0.5	-0.1...+0.9	-0.1...+1.5	-0.1...+2.4
psi	-14.5...0 ¹⁾	-14.5...+15 ¹⁾	-14.5...+30	-14.5...+50	-14.5...+100	-14.5...+160	-14.5...+200	-14.5...+300

1) Not available for G ½ Flat embedded diaphragm process connection

The specified measuring range can also be kg/cm and bar.

Special measuring ranges can be provided as required: 0...0.04 and 0 ... 100mpa (0 ... 10bis 0 ... 7,500psi).

Using special measuring range will reduce long-term stability and increase temperature error.

Overvoltage limit

The overvoltage limit is determined by the sensor element used. Depending on the selected process connection and sealing, the overpressure safety can be limited.

≤ 60 MPa (< 8,000 psi): 2 times

> 100 MPa (≥ 8,000 psi): 1.5 times

Enhanced overvoltage safety (optional)

When choosing to enhance overvoltage safety, there will be deviations in temperature error, signal noise and long-term stability.

PTD200-Selection composition

Selection example PTD200

1	A	2	G	3	N	4	S	5	U	6	A	7	Z
---	---	---	---	---	---	---	---	---	---	---	---	---	---

1.Measuring range (MPa)	A	-1...0
	B	0...0.1
	C	0...25
	D	0...40
	E	0...60
	F	0...100
2.Output signal	G	4-20mA
	H	1-5V DC
	I	0-5V DC
	J	0-10V DC
3.Contact signal	N	Normally open
	O	Normal close
4.Liquid material	S	304SS
	L	316L
5.Process connection	M	G1/2
	U	G1/4
	V	M14*1.5
	W	M20*1.5
	X	M27*1.5
	Y	1/2NPT
	Z	1/4NPT
T ()	Other specifications	
6.Shell material	A	304SS
	B	316L
	T ()	Other materials
7.Electrical interface	Z	M12*1
	T ()	Other electrical interfaces

Instructions:

It indicates that the measuring range of PTD-200 digital pressure switch is -1...0MPa, the output signal is 4-20mA, the contact signal is normally open, the liquid contact material is 304 stainless steel, the screw interface is G1/4, the shell material is 304 stainless steel, and the electrical interface is M12*1.

Product Certification

Compliance and approval; Rodewig pressure transmitters meet key standards and certifications for process measurement technology; Thus guaranteeing the highest reliability in such Settings;